

**Set reti di protezione radiatori acqua - 97381981AA****Water radiator protective mesh set - 97381981AA****Simbologia**

Per una lettura rapida e razionale sono stati impiegati simboli che evidenziano situazioni di massima attenzione, consigli pratici o semplici informazioni. Prestare molta attenzione al significato dei simboli, in quanto la loro funzione è quella di non dovere ripetere concetti tecnici o avvertenze di sicurezza. Sono da considerare, quindi, dei veri e propri "promemoria". Consultare questa pagina ogni volta che sorgessero dubbi sul loro significato.

**Attenzione**

La non osservanza delle istruzioni riportate può creare una situazione di pericolo e causare gravi lesioni personali e anche la morte.

**Importante**

Indica la possibilità di arrecare danno al veicolo e/o ai suoi componenti se le istruzioni riportate non vengono eseguite.

**Note**

Fornisce utili informazioni sull'operazione in corso.

**Riferimenti**

I particolari evidenziati in grigio e riferimento numerico (Es. ①) rappresentano l'accessorio da installare e gli eventuali componenti di montaggio forniti a set.

I particolari con riferimento alfabetico (Es. (A)) rappresentano i componenti originali presenti sul motoveicolo.

Tutte le indicazioni destro o sinistro si riferiscono al senso di marcia del motociclo.

**Avvertenze generali****Attenzione**

Le operazioni riportate nelle pagine seguenti devono essere eseguite da un tecnico specializzato o da un'officina autorizzata Ducati.

**Attenzione**

Le operazioni riportate nelle pagine seguenti se non eseguite a regola d'arte possono pregiudicare la sicurezza del pilota.

**Note**

Documentazione necessaria per eseguire il montaggio del Set è il Manuale Officina, relativo al modello di moto in vostro possesso.

**Note**

Nel caso fosse necessaria la sostituzione di un componente del set consultare la tavola ricambi allegata.

**Symbols**

To allow quick and easy consultation, this manual uses graphic symbols to highlight situations in which maximum care is required, as well as practical advice or information. Pay attention to the meaning of the symbols since they serve to avoid repeating technical concepts or safety warnings throughout the text. The symbols should therefore be seen as real "reminders". Please refer to this page whenever in doubt as to their meaning.

**Warning**

Failure to comply with these instructions may put you at risk and lead to severe injury or even death.

**Important**

Failure to comply with these instructions may lead to serious damage to the motorcycle and/or its components.

**Notes**

It provides useful information about the current operation.

**References**

The parts highlighted in grey and with a reference number (e.g. ①) represent the accessory to be installed and any assembly components supplied with the set.

The parts with alphabetic reference (e.g. (A)) represent the original components present on the motorcycle.

All left and right indications are referred to the motorcycle direction of travel (forward riding position).

**General notes****Warning**

The operations listed in the following pages must be carried out by a specialised technician or by a Ducati authorised service centre.

**Warning**

Carefully perform the operations on the following pages since they might negatively affect rider safety.

**Notes**

The Workshop Manual specific for your bike model is the documentation required to assemble the set.

**Notes**

If a set component needs to be replaced, refer to the attached spare parts table.

**Warning**

Operating, servicing and maintaining a passenger vehicle or off-highway motor vehicle can expose you to chemicals including engine exhaust, carbon monoxide, phthalates, and lead, which are known to the State of California to cause cancer and birth defects or other reproductive harm. To minimize exposure, avoid breathing exhaust, do not idle the engine except as necessary, service your vehicle in a well-ventilated area and wear gloves or wash your hands frequently when servicing your vehicle. For more information go to [www.P65Warnings.ca.gov/passenger-vehicle](http://www.P65Warnings.ca.gov/passenger-vehicle).

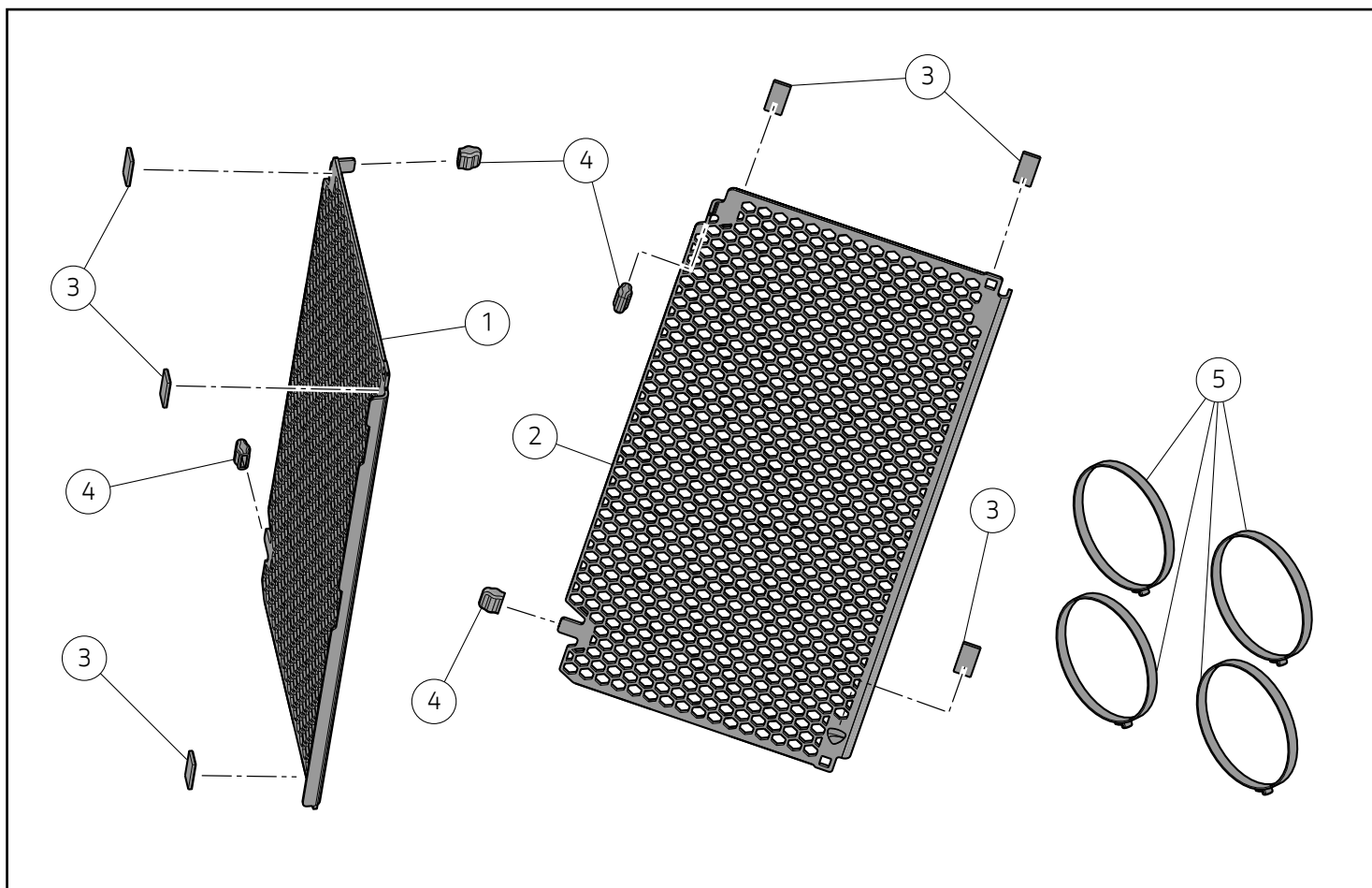

### ● Importante

I componenti del set possono essere soggetti ad aggiornamenti; consultare il DCS (Dealer Communication System) per avere informazioni sempre aggiornate.

### ● Important

Set components may be subject to upgrades; refer to the DCS (Dealer Communication System) for updated information.

Pos.	Denominazione	Name
1	Rete protezione radiatore destro	RH radiator protective mesh
2	Rete protezione radiatore sinistro	LH radiator protective mesh
3	Tampone di supporto	Support buffer
4	Tampone in gomma	Rubber block
5	Fascetta	Clamp

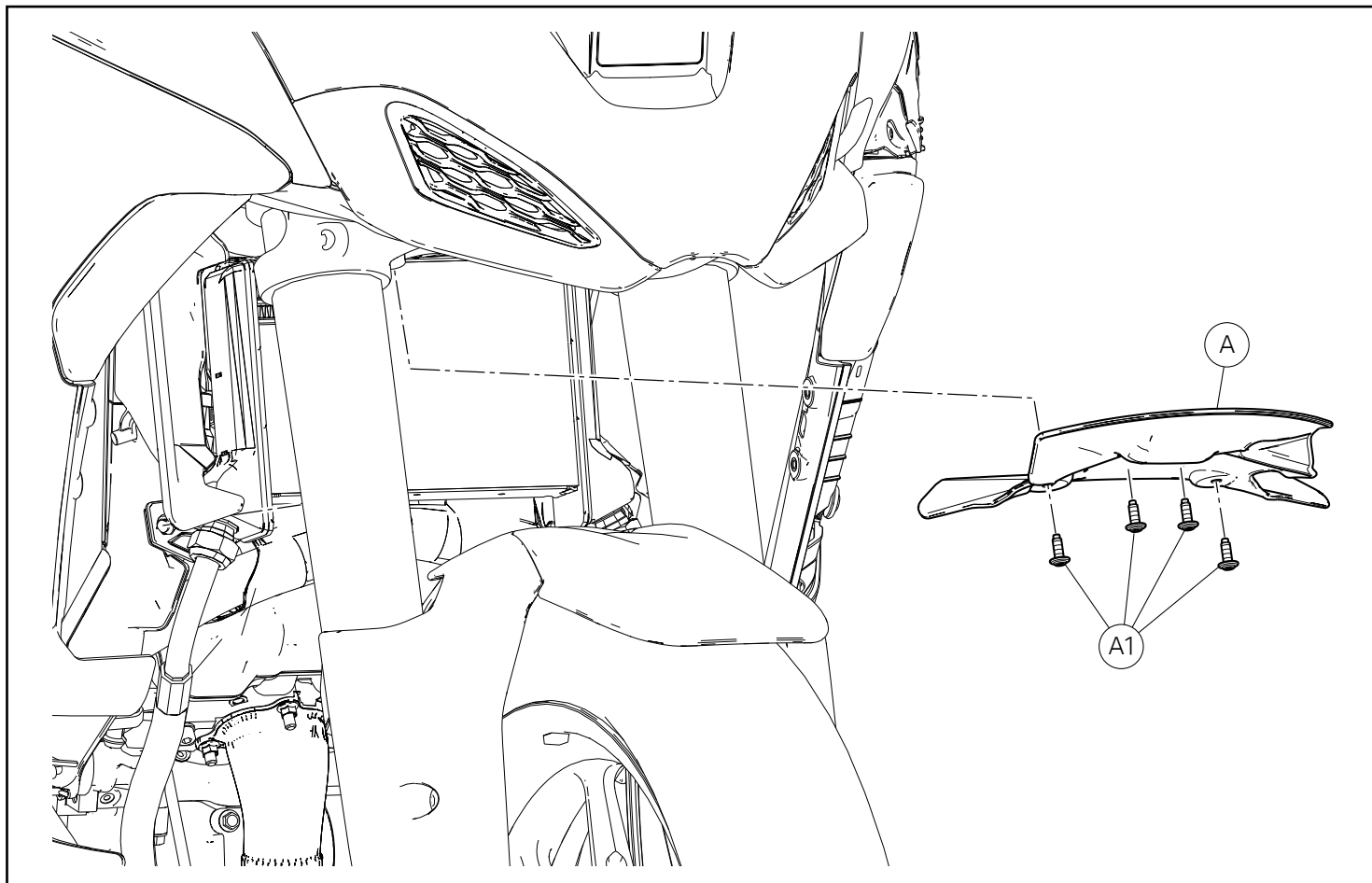

### Smontaggio componenti originali

#### Smontaggio paraspruzzi anteriore

Svitare le n.4 viti (A1) e rimuovere il paraspruzzi anteriore (A).  
Recuperare n.4 viti (A1).

### Removing the original components

#### Removing the front splash guard

Loosen no.4 screws (A1) and remove the front splash guard (A).  
Collect no.4 screws (A1).

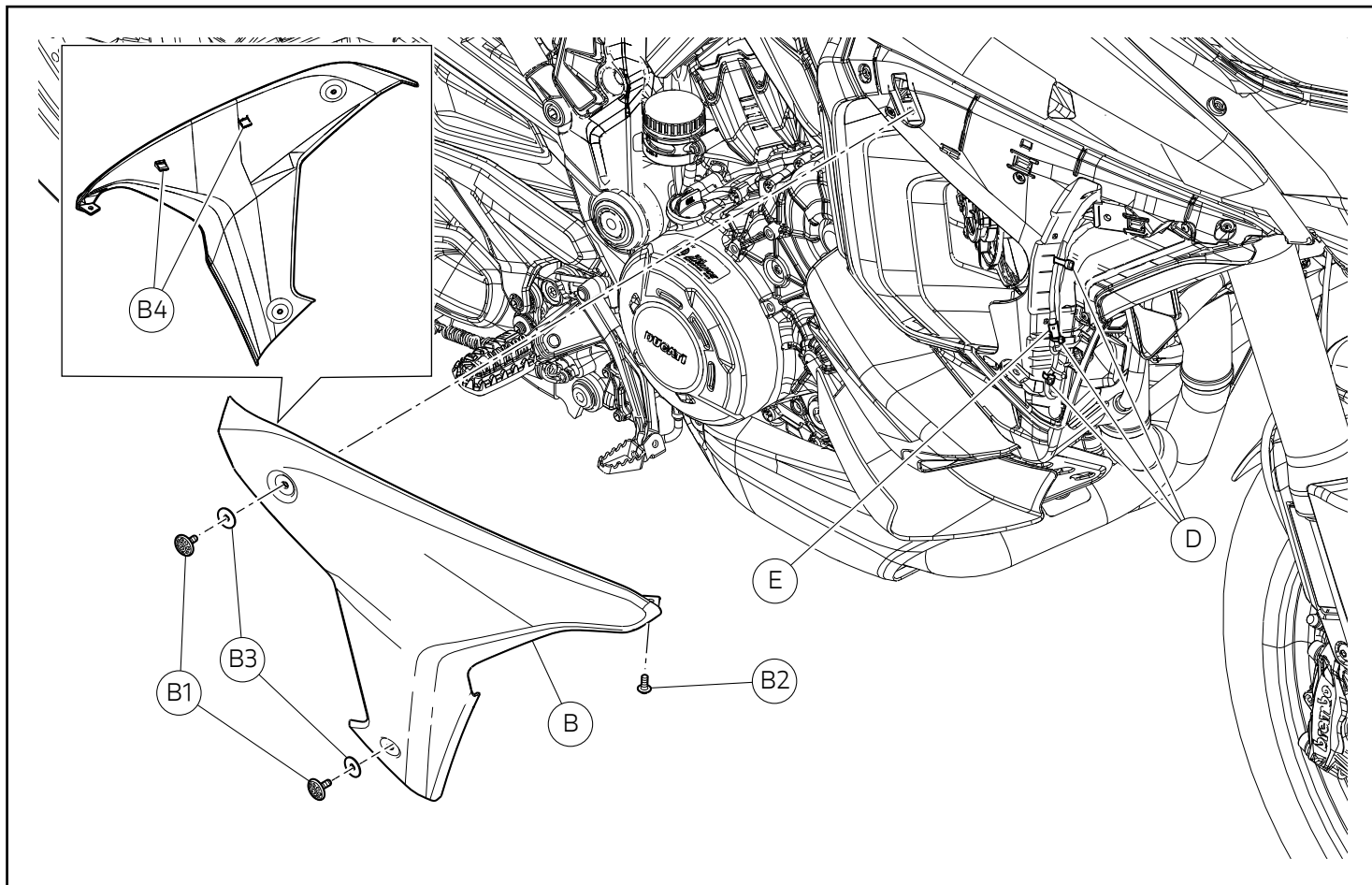

### Smontaggio cover laterale

Svitare le n.2 viti (B1), la n.1 vite (B2) e recuperare le n.2 rosette (B3). Rimuovere la cover laterale tirandola verso l'esterno, sganciando le n.2 alette (B4). Rimuovere le n.3 fascette (D) e scollegare il connettore (E). Ripetere l'operazione dal lato sinistro del veicolo.

### Removing the side cover

Loosen no.2 screws (B), no.1 screw (B2) and collect no.2 washers (B3). Remove side cover by pulling it outwards and release the no.2 tabs (B4). Remove no.3 ties (D) and disconnect connector (E). Repeat the same procedure on the left side of the vehicle.

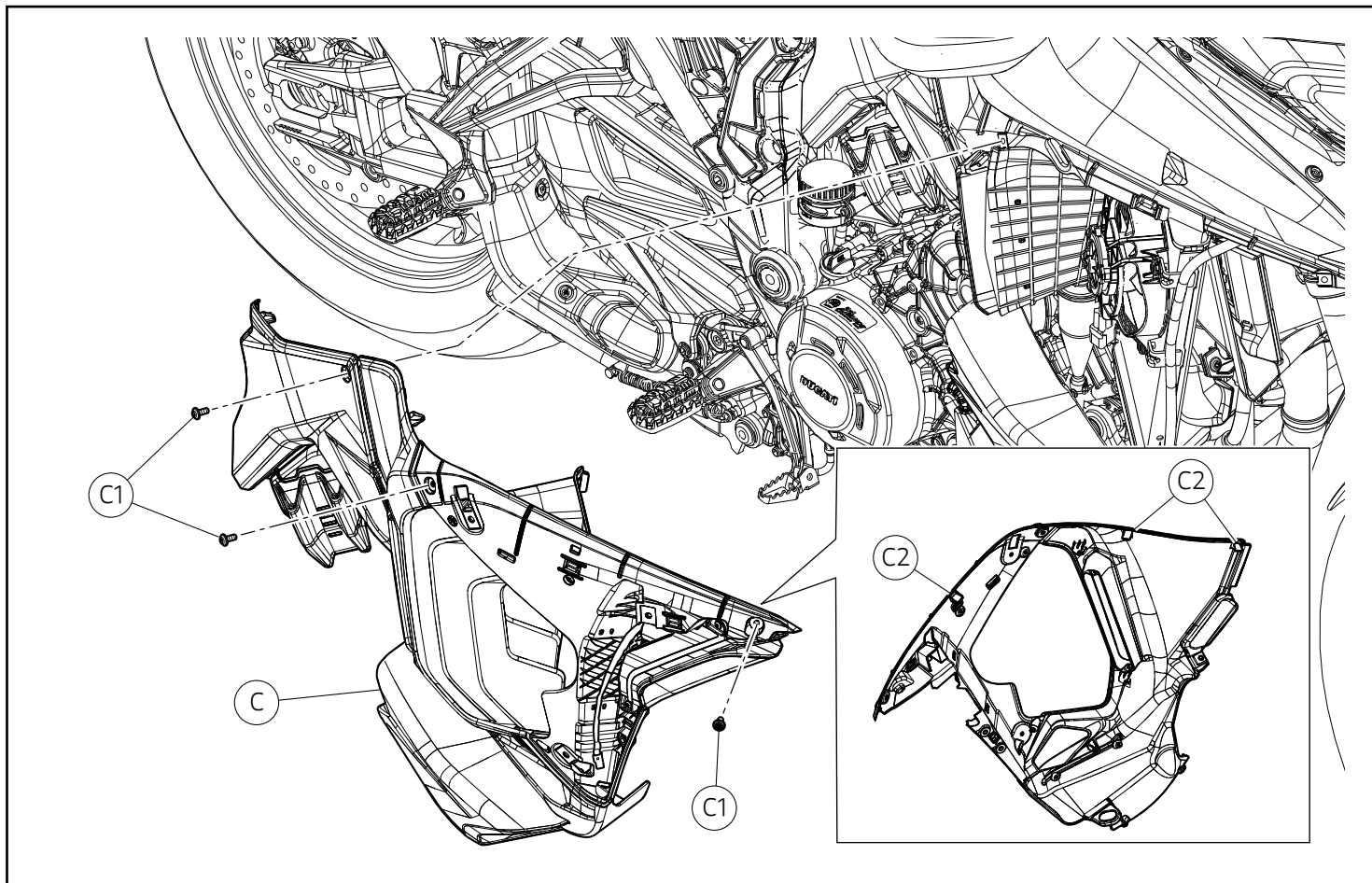

### Smontaggio struttura cover laterale

Svitare le n.3 viti (C1) e scollegare, dalle apposite sedi, le n.3 mollette (C2). Rimuovere la struttura cover laterale (C) verso l'esterno. Ripetere l'operazione dal lato sinistro del veicolo.

### Removing the side cover structure

Loosen no.3 screws (C1) and disconnect no.3 clips (C2) from their seats. Remove side cover structure (C) by pulling it outwards. Repeat the same procedure on the left side of the vehicle.

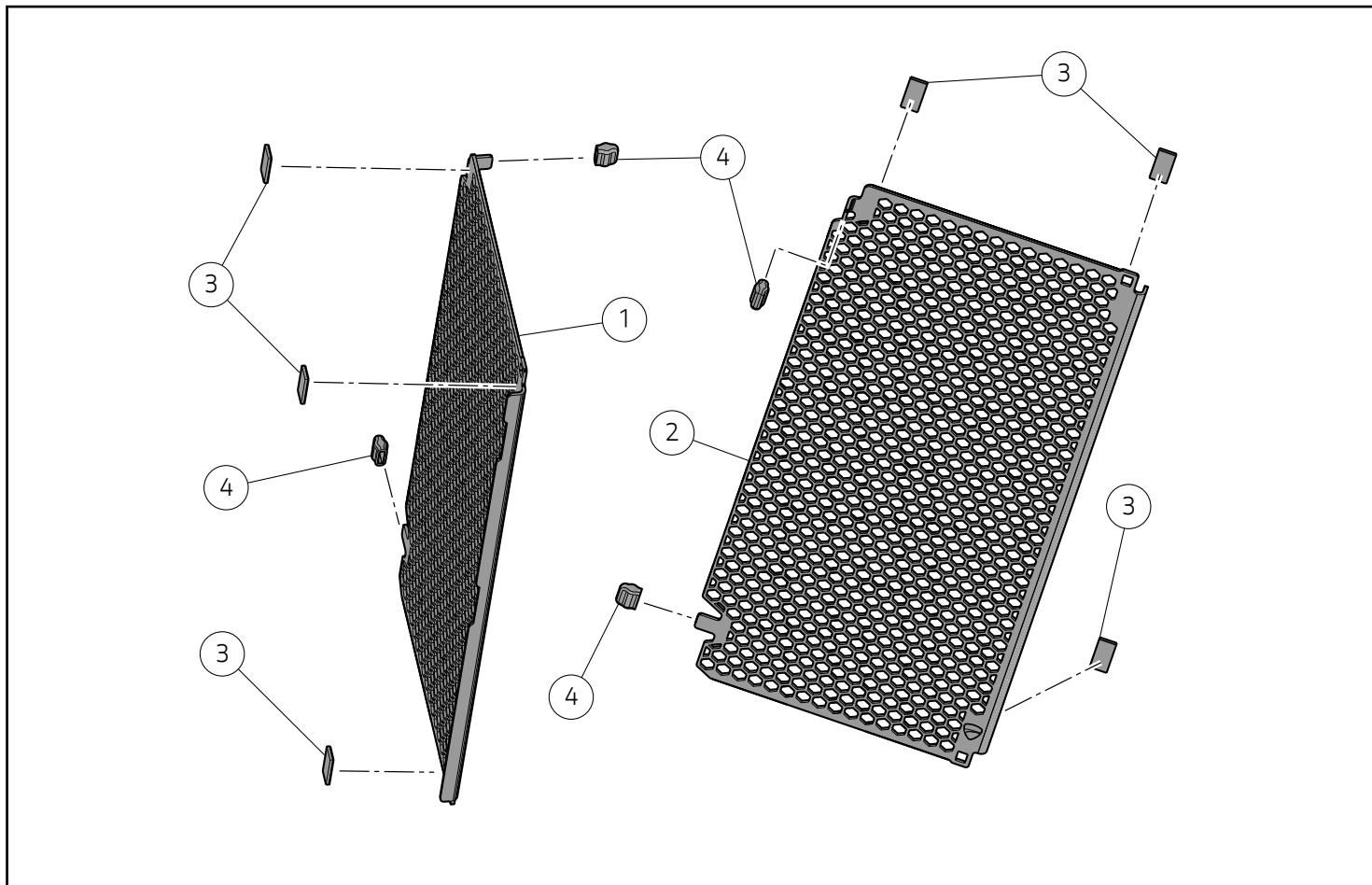

## Montaggio componenti set

### ● Importante

Verificare, prima del montaggio, che tutti i componenti risultino puliti e in perfetto stato. Adottare tutte le precauzioni necessarie per evitare di danneggiare qualsiasi parte nella quale ci si trova ad operare.

### Premontaggio protezioni radiatori

Applicare sulle protezioni radiatori (1) e (2) n.6 tamponi di supporto (3) e n.4 tamponi in gomma (4).

## Assembling the set components

### ● Important

Before assembly, make sure that all parts are clean and in perfect conditions. Take all the necessary measures to avoid damaging any part you are working on.

### Pre-assembling the radiator protections

Apply no.6 support buffers (3) and no.4 rubber blocks (4) on radiator protections (1) and (2).

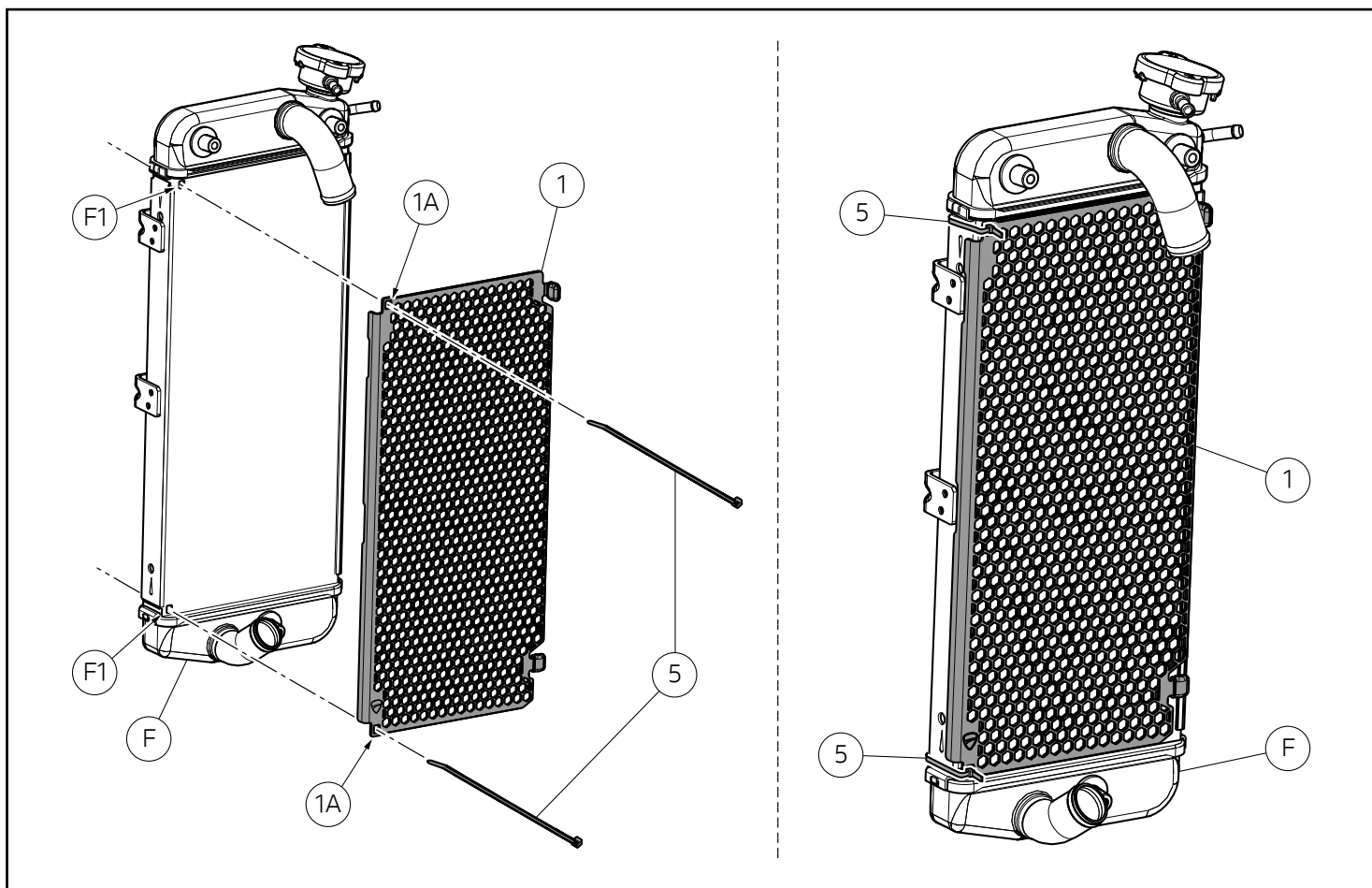

### Montaggio protezioni radiatori



#### Note

Per una più semplice comprensione delle procedure di montaggio vengono rappresentati solamente i componenti interessati.



#### Note

Per eseguire le procedure di montaggio, non è necessario rimuovere i radiatori.

Posizionare la protezione radiatore (1) sul radiatore destro (F), orientandola come mostrato in figura. Fissare la protezione radiatore (1) applicando n.2 fascette (5), inserendole attraverso le apposite fessure (1A), sulla protezione (1), e le fessure (F1) sul radiatore destro (F). orientare le n.2 fascette (5) come mostrato in figura. Ripetere le stesse operazioni, per fissare la protezione sul radiatore sinistro.

### Assembling the radiator protections



#### Notes

For an easier understanding of the assembly procedure, only the involved components are shown.



#### Notes

To carry out the assembly procedures, radiators do not have to be removed.

Position radiator protection (1) on RH radiator (F), aiming it as shown in the figure. Secure radiator protection (1) with no.2 ties (5) to be inserted inside the special slots (1A) on protection (1) and slots (F1) on RH radiator (F). Aim no.2 ties (5) as shown in the figure. Repeat the same operations to secure the protection on the LH radiator.

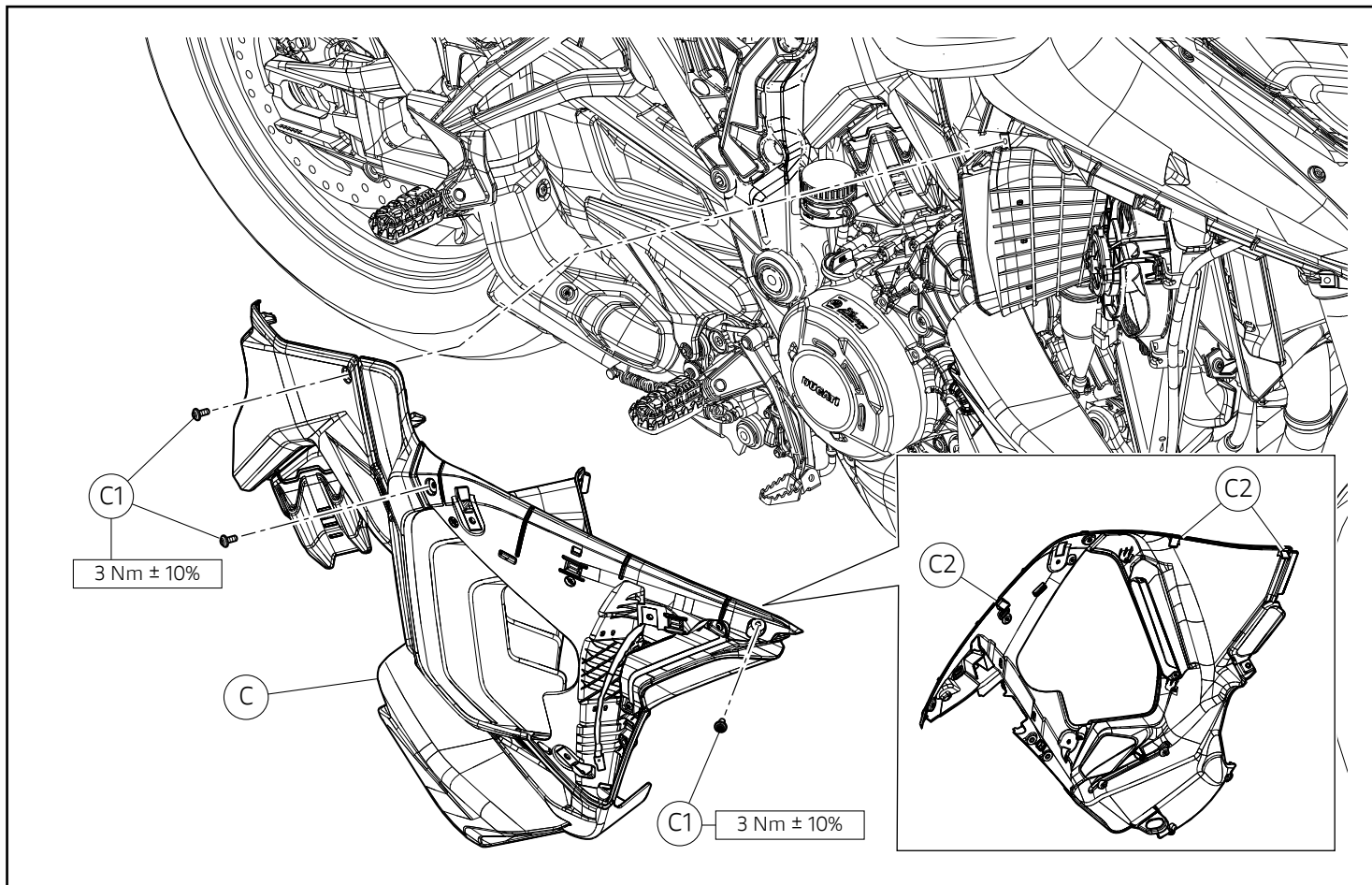

### Rimontaggio struttura cover laterale

Applicare la struttura cover laterale (C) sul veicolo inserendo nuovamente il cablaggio precedentemente rimosso e collegare, nelle apposite sedi, le n.3 mollette (C2). Inserire le n.3 viti (C1) e serrarle alla coppia prescritta. Ripetere l'operazione dal lato sinistro del veicolo.

### Refitting the side cover structure

Apply the side cover structure (C) on the vehicle by inserting again the previously-removed wiring, and connect no.3 clips (C2) in the special seats. Insert no.3 screws (C1), and tighten to the specified torque. Repeat the same procedure on the left side of the vehicle.



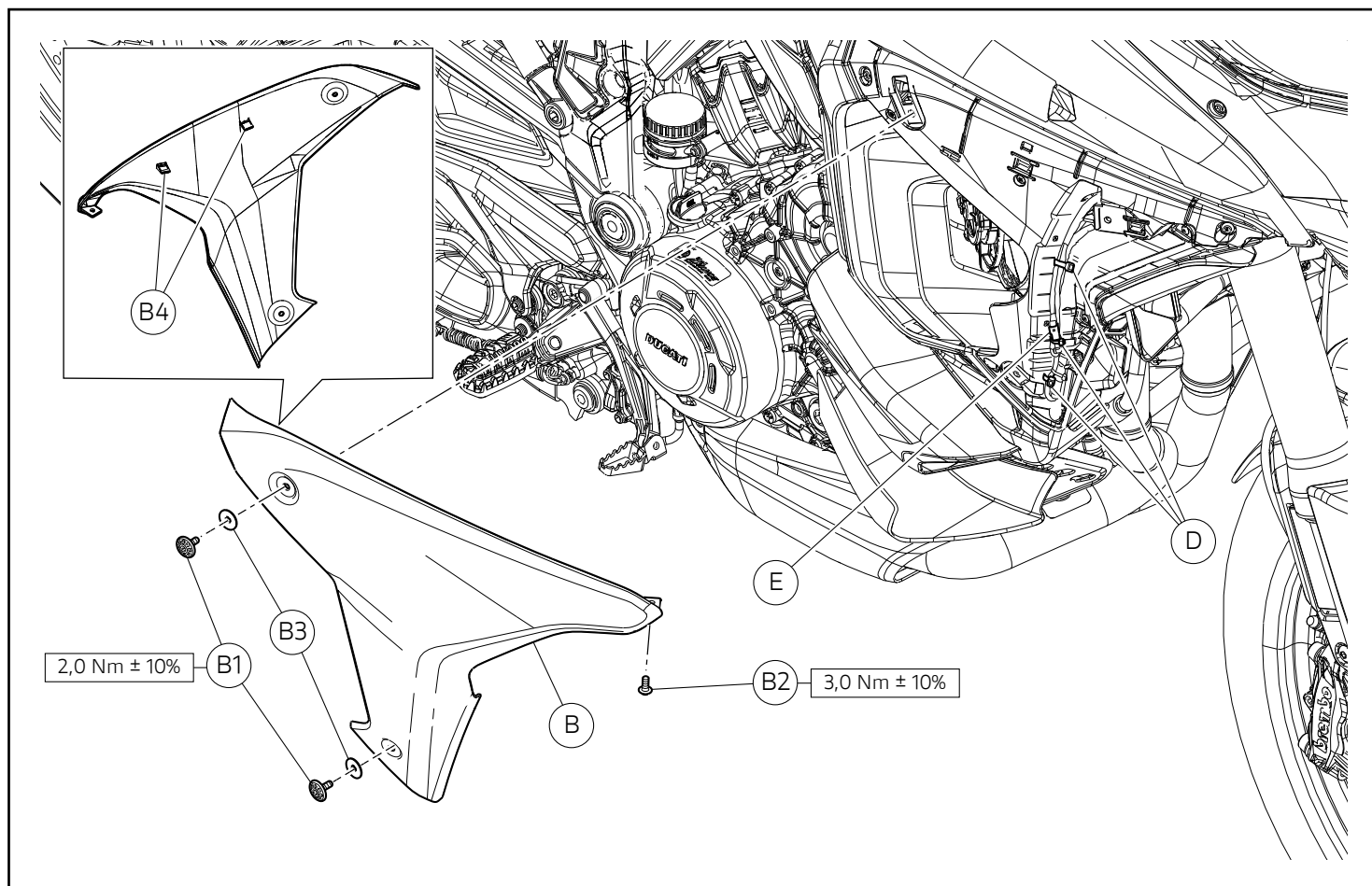

### Rimontaggio cover laterale

Applicare la cover laterale facendo combaciare le n.2 alette (B4) nelle apposite sedi. Inserire le n.2 viti (B1) assieme le n.2 rosette (B3) e serrarle alla coppia indicata. Impuntare la n.1 vite (B2). Serrare la n.1 vite (B2) alla coppia indicata. Ripetere l'operazione dal lato sinistro del veicolo.

### Refitting the side cover

Apply the side cover by matching no.2 tabs (B4) with the relevant seats. Insert no.2 screws (B1) with no.2 washers (B3) and tighten to the specified torque. Start no.1 screw (B2). Tighten no.1 screw (B2) to the specified torque. Repeat the same procedure on the left side of the vehicle.

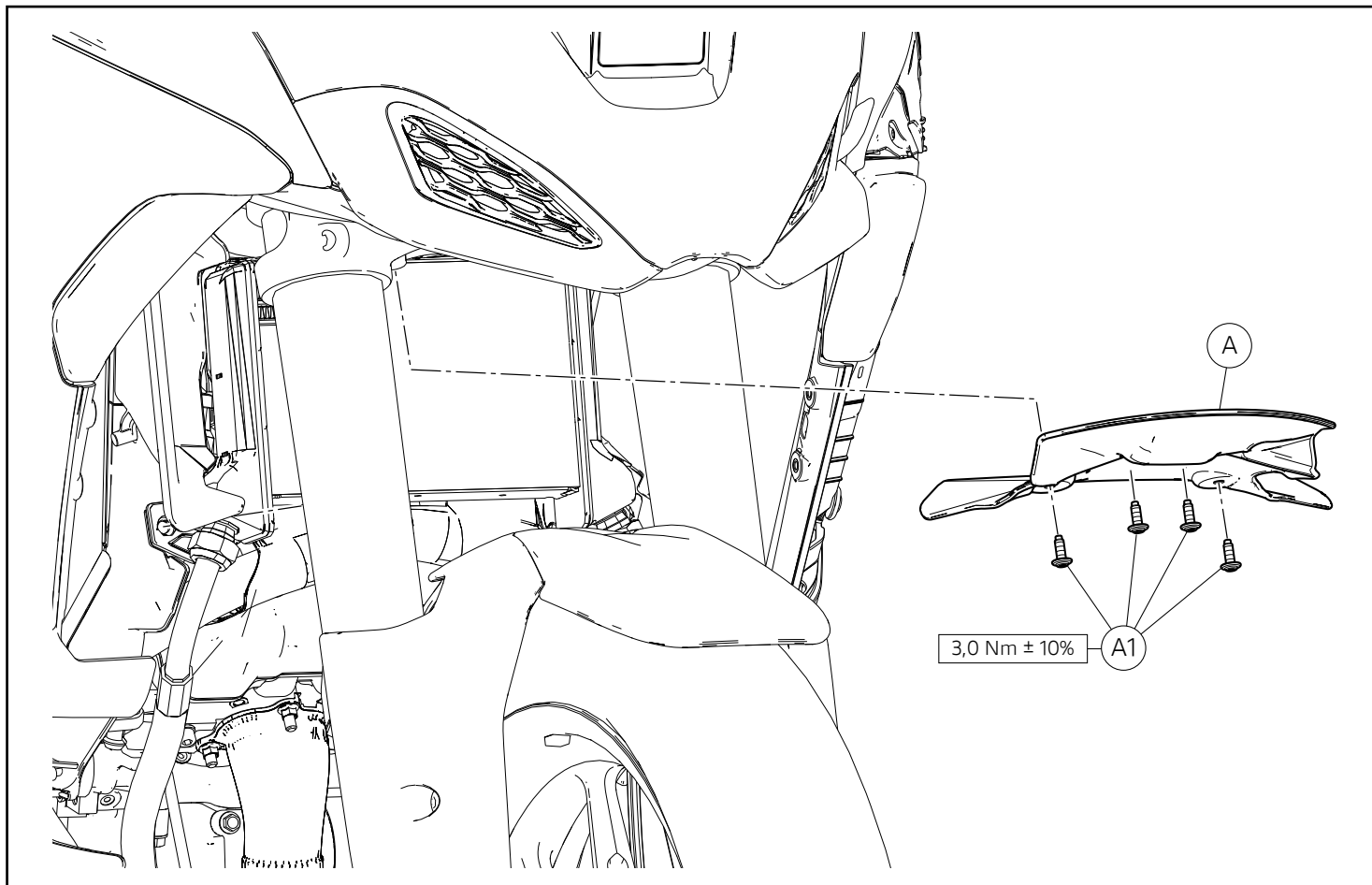

### Rimontaggio paraspruzzi

Applicare il paraspruzzi (A) sul veicolo. Impuntare le n.4 viti (A1).  
Serrare le n.4 viti (A1) alla coppia indicata.

### Refitting the splash guard

Fit splash guard (A) to vehicle. Start no.4 screws (A1). Tighten no.4  
screws (A1) to the specified torque.

# レース専用部品 ご注文書

## ご注文商品

1	P/N	商品名
2	P/N	商品名
3	P/N	商品名
4	P/N	商品名
5	P/N	商品名

## お客様ご記入欄

私は上記レース専用部品を下記車両に装着し、サーキット走行のみに利用し、一般公道には利用しません。

車台番号 ZDM	モデル名
お客様署名	ご注文日

## ドウカティ正規ネットワーク店記入欄

お客様に上記レース専用部品を販売し、レース専用部品のご利用方法を説明いたしました。

販売店署名	販売日	年	月	日
-------	-----	---	---	---

販売店様へお願い

- 上記ご記入の上、弊社アフターセールス部までFAXしてください。FAX : 03 - 6692 - 1317
- 取り付け車両 1台に 1枚でご使用ください。

Set reti di protezione radiatori acqua / Water radiator protective mesh set / Jeu grilles de protection pour radiateurs eau / Set Schutzgitter für Wasserkühler / Conjunto de redes de proteção dos radiadores de água / 水散热器保护网套件 / Set redes de protección radiadores agua / ラジエータープロテクショングリッドセット - 97381981AA

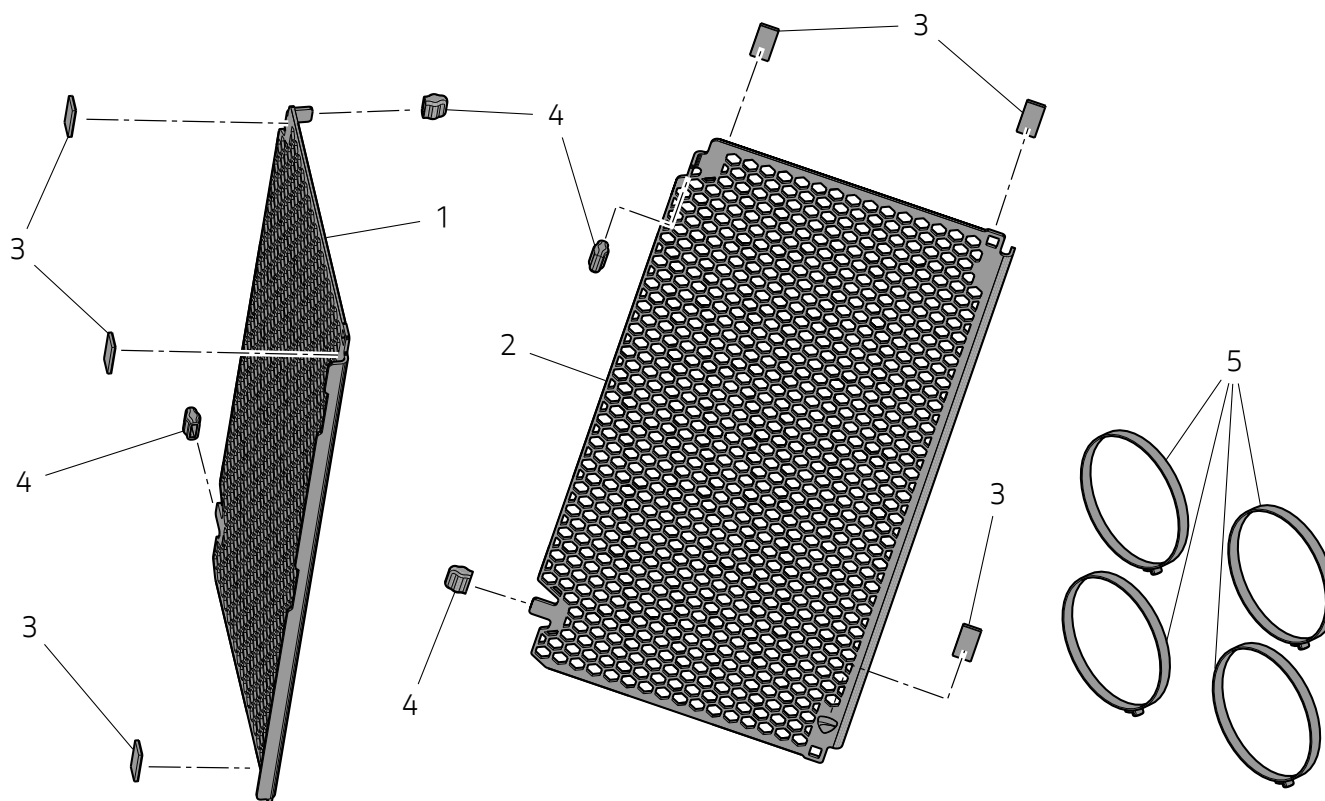

Pos.	Cod.	Nome	Name	Nom	Name	Nome	名称	Nombre	名称	Q.ty
1	97312401AA	Rete protezione radiatore dx	RH radiator protective mesh	Grille de protection radiateur drt	Rechtes Kühlerschutzgitter	Rede de proteção do radiador direito	右散热器保护网	Red protección radiador dcha.	右ラジエータープロテクショングリッド	1
2	97312411AA	Rete protezione radiatore sx	LH radiator protective mesh	Grille de protection radiateur gche	Linkes Kühlerschutzgitter	Rede de proteção do radiador esquerdo	左散热器保护网	Red protección radiador izq.	左ラジエータープロテクショングリッド	1
3	86613041A	Tampone di supporto	Support buffer	Tampon de support	Stützstopfen	Tampão de suporte	支撑缓冲器	Tope de soporte	マウントパッド	6
4	86613311A	Tampone in gomma	Rubber block	Tampon en caoutchouc	Gummipuffer	Tampão de borracha	橡胶缓冲器	Tope de goma	ラバーバッファー	4
5	97641891AA	Fascetta	Clamp	Collier serre-flex	Schelle	Braçadeira	固定夹	Abrazadera	クランプ	4