

Kit cupolino Headlight fairing kit



Simbologia

Per una lettura rapida e razionale sono stati impiegati simboli che evidenziano situazioni di massima attenzione, consigli pratici o semplici informazioni.

Prestare molta attenzione al significato dei simboli, in quanto la loro funzione è quella di non dovere ripetere concetti tecnici o avvertenze di sicurezza. Sono da considerare, quindi, dei veri e propri "promemoria".

Consultare questa pagina ogni volta che sorgeranno dubbi sul loro significato.



Attenzione

La non osservanza delle istruzioni riportate può creare una situazione di pericolo e causare gravi lesioni personali e anche la morte.



Importante

Indica la possibilità di arrecare danno al veicolo e/o ai suoi componenti se le istruzioni riportate non vengono eseguite.



Note

Fornisce utili informazioni sull'operazione in corso.

Riferimenti

I particolari evidenziati in grigio e riferimento numerico (Es. ①) rappresentano l'accessorio da installare e gli eventuali componenti di montaggio forniti a kit.

I particolari con riferimento alfabetico (Es. A) rappresentano i componenti originali presenti sul motoveicolo.

Tutte le indicazioni destro o sinistro si riferiscono al senso di marcia del motociclo.

Avvertenze generali



Attenzione

Le operazioni riportate nelle pagine seguenti devono essere eseguite da un tecnico specializzato o da un'officina autorizzata DUCATI.



Attenzione

Le operazioni riportate nelle pagine seguenti se non eseguite a regola d'arte possono pregiudicare la sicurezza del pilota.



Note

Documentazione necessaria per eseguire il montaggio del Kit è il MANUALE OFFICINA, relativo al modello di moto in vostro possesso.



Note

Nel caso fosse necessaria la sostituzione di un componente del kit consultare la tavola ricambi allegata.

Symbols

To allow quick and easy consultation, this manual uses graphic symbols to highlight situations in which maximum care is required, as well as practical advice or information.

Pay attention to the meaning of the symbols since they serve to avoid repeating technical concepts or safety warnings throughout the text. The symbols should therefore be seen as real reminders. Please refer to this page whenever in doubt as to their meaning.



Warning

Failure to follow these instructions might give rise to a dangerous situation and provoke severe personal injuries or even death.



Caution

Failure to follow these instructions might cause damages to the vehicle and/or its components.



Notes

Useful information on the procedure being described.

References

Parts highlighted in grey and with a numeric reference (Example ①) are the accessory to be installed and any assembly components supplied with the kit.

Parts with an alphabetic reference (Example A) are the original components fitted on the vehicle.

Any right- or left-hand indication refers to the vehicle direction of travel.

General notes



Warning

Carefully perform the operations on the following pages since they might negatively affect rider safety.



Warning

Carefully perform the operations on the following pages since they might negatively affect rider safety.



Notes

The following documents are necessary for assembling the Kit: WORKSHOP MANUAL of your bike model.



Notes

Should it be necessary to change any kit parts, please refer to the attached spare part table.

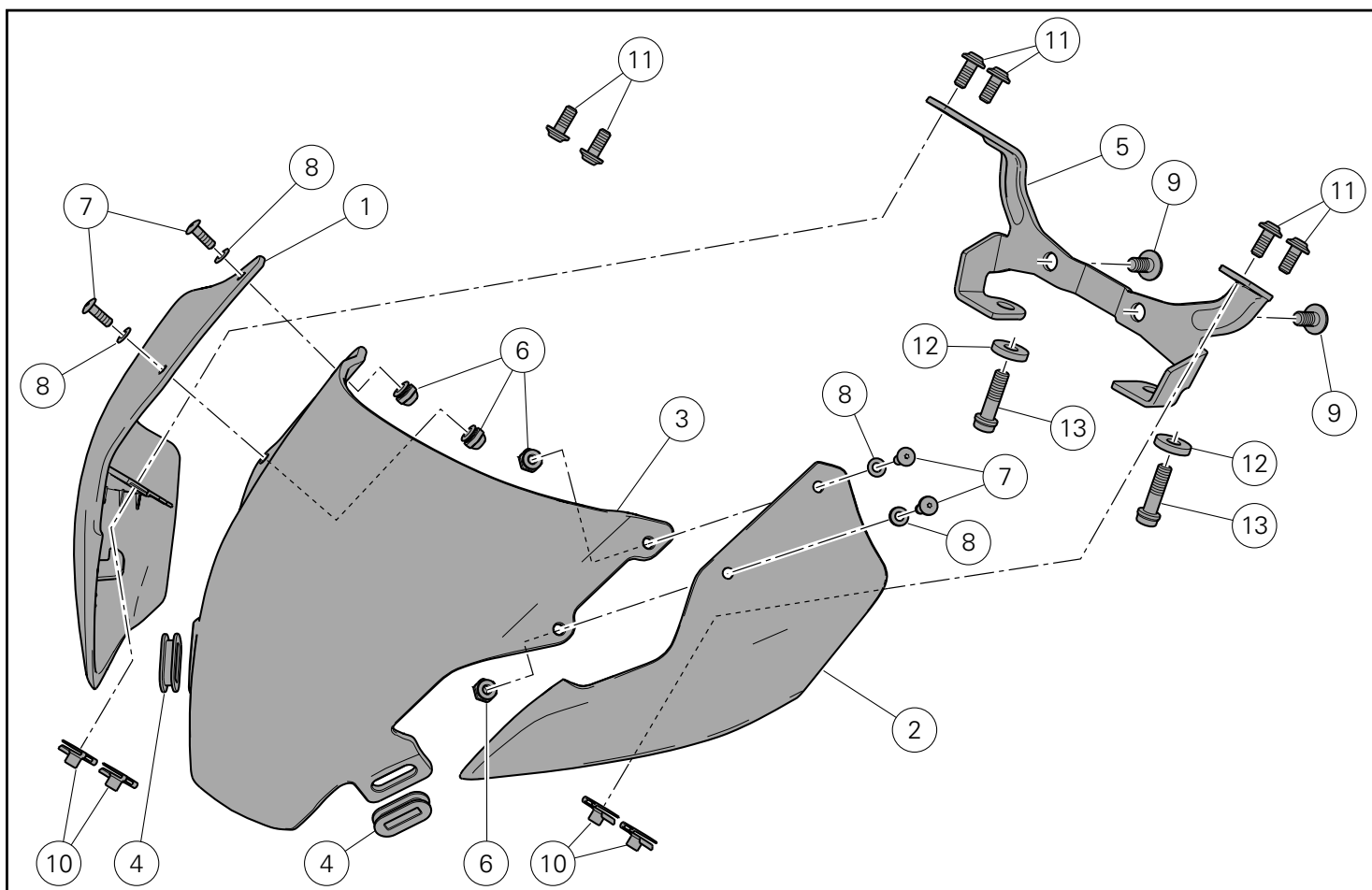

Pos.	Denominazione	Description
1	Guancia cupolino destra	RH headlight fairing panel
2	Guancia cupolino sinistra	LH headlight fairing panel
3	Parabrezza centrale	Central windscreen
4	Gommino	Rubber block
5	Staffa supporto cupolino	Headlight fairing support bracket
6	Dado elastico	Spring nut
7	Vite speciale TB M4x12	TB special screw M4x12
8	Rosetta in nylon	Nylon washer
9	Vite TBEIF M6x12	TBEIF screw M6x12
10	Clip	Clip
11	Vite TBEI M5x12	TBEI screw M5x12
12	Rosetta	Washer
13	Vite TCEIF M6x22	TCEIF screw M6x22

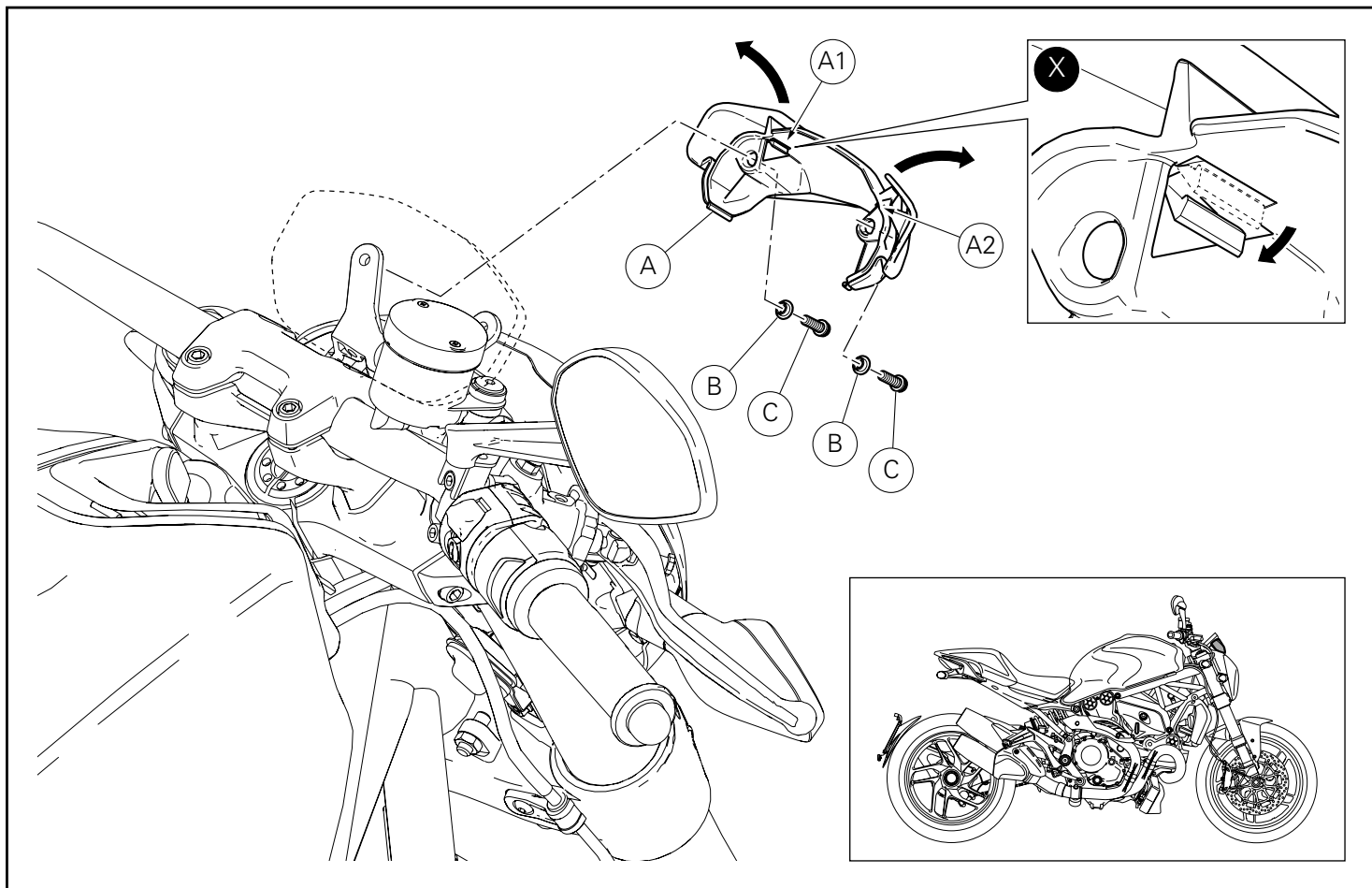

Smontaggio componenti originali

Note

La procedura di montaggio del kit è la stessa per tutti i motoveicoli Monster 1200 e Monster 821, per cui viene utilizzata, come esempio, la procedura da adottare sul modello Monster1200.

Aprire le due alette della cover cruscotto (A) sganciando i due dentini (A1) e (A2), come indicato in figura (X).
Svitare le n.2 viti (C) e rimuovere i n.2 distanziali (B) e la cover cruscotto (A).

Removing the original components

Notes

The kit installing procedure is the same for all 1200 and Monster 821 motorcycles. The procedure for Monster 1200 will be described here as a general example.

Open the two tabs of instrument panel cover (A) by disengaging the two teeth (A1) and (A2), as shown in figure (X).
Release the n.2 screws (C) and remove the n.2 spacers (B) and the instrument panel cover (A).

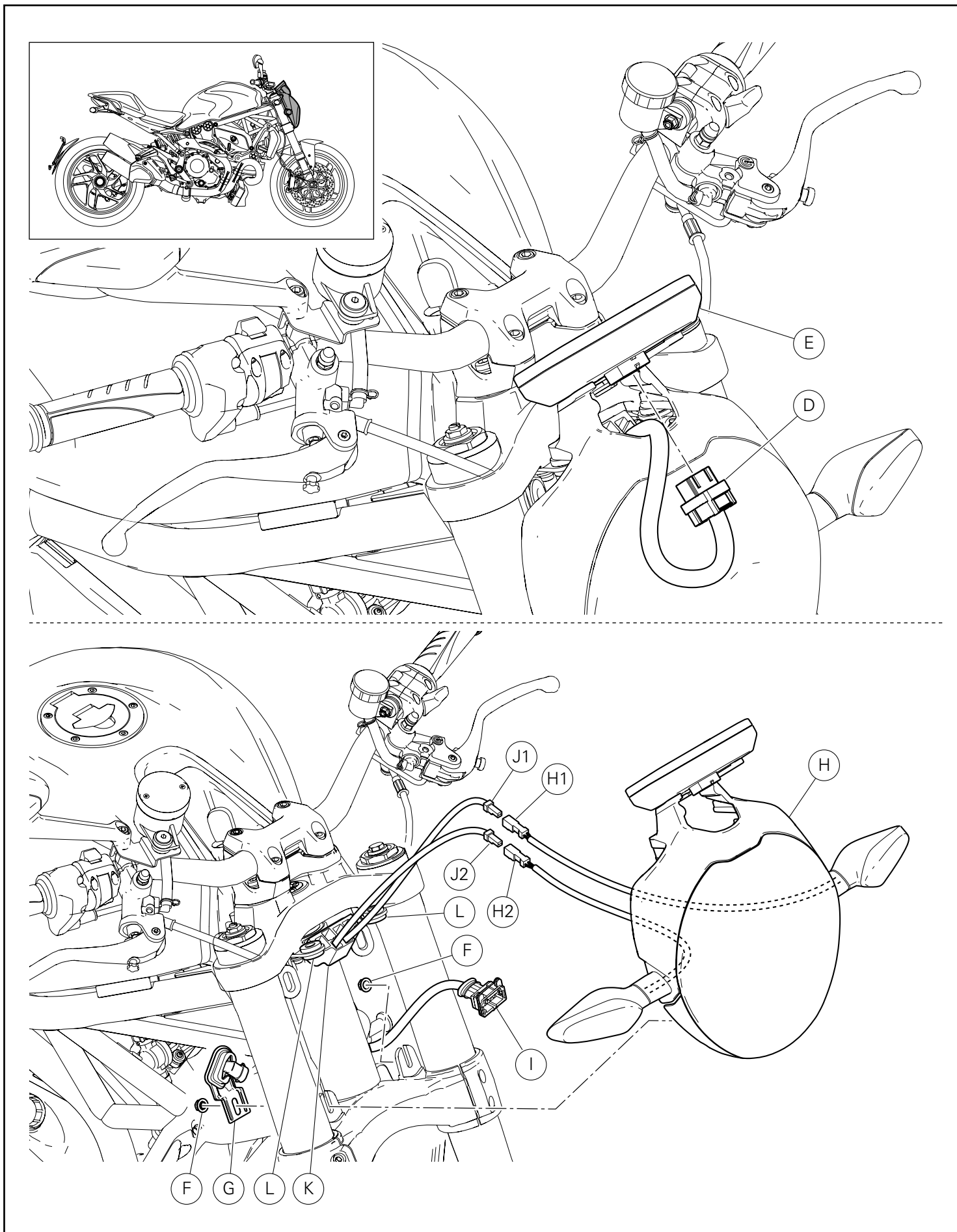

Scollegare la connessione (D) dal cruscotto (E).

Svitare i n.2 dadi (F).



Importante

Durante la fase di smontaggio del dado destro prestare attenzione a non rovinare il sensore temperatura aria (G) supportandolo adeguatamente.

Scollegare la spina (I) dalla rispettiva presa presente sul gruppo fanale anteriore (H).

Rimuovere il gruppo fanale anteriore (H) sganciandolo dai gommini antivibranti (L).

Estrarre il collegamento degli indicatori di direzione dal supporto connettori (K).

Scollegare le prese (H1) e (H2) degli indicatori di direzione dalle rispettive spine (J1) e (J2) del cablaggio principale.

Disconnect wiring connectors (D) from instrument panel (E).

Loosen n.2 nuts (F).



Caution

While releasing the right nut, make sure that the air temperature sensor (G) is not damaged, and properly support it.

Disconnect the plug (I) from its socket on the front light assembly (H).

Remove headlight assembly (H) by disconnecting it from vibration damper rubber blocks (L).

Remove the turn indicators connectors from connector mounting plate (K).

Disconnect turn indicator plug (H1) and (H2) from their sockets (J1) and (J2) in the main wiring.

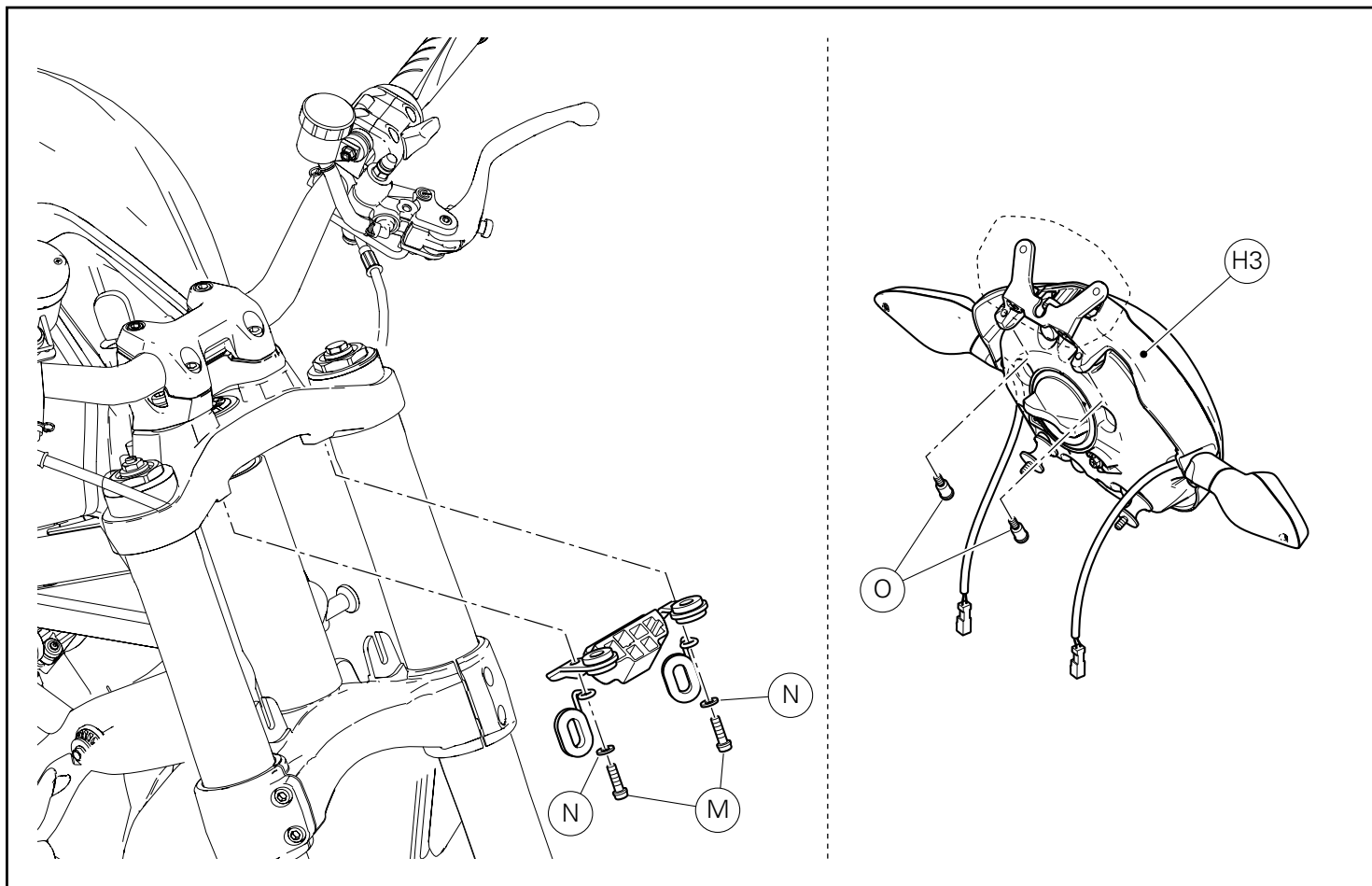

Svitare le n.2 viti (M) e le n.2 rondelle (N).
Recuperare le n.2 rondelle (N).

Svitare i n.2 perni filettati (O) dal supporto fanale (H3).

Loosen no. 2 screws (M) and no. 2 washers (N).
Keep no. 2 washers (N).

Release n.2 threaded pins (O) from headlight support (H3).

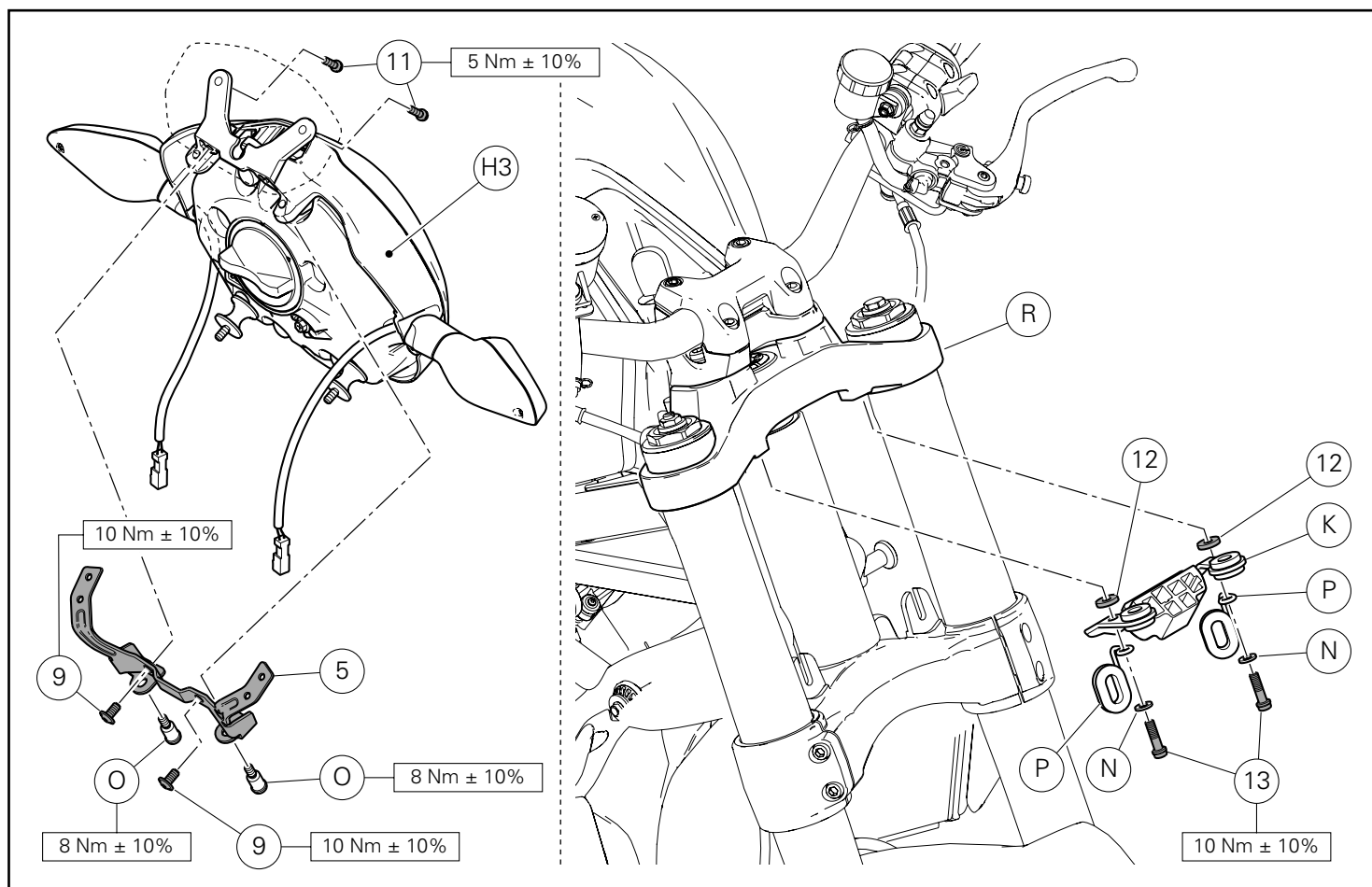

Montaggio componenti kit

● Importante

Verificare, prima del montaggio, che tutti i componenti risultino puliti e in perfetto stato.
Adottare tutte le precauzioni necessarie per evitare di danneggiare qualsiasi parte nella quale ci si trova ad operare.

Impuntare e serrare le n.2 viti (11) alla coppia indicata.
Posizionare la staffa supporto cupolino (5) e impuntare le n.2 viti (9) senza serrarle.
Avvitare i n.2 perni filettati originali (O) sul supporto fanale (H3) interponendo la staffa (5).
Serrare i n.2 perni filettati (O) e le n.2 viti (9) alla coppia indicata.

Inserire i n.2 passatubi (P) e le n.2 rondelle (N) nelle n.2 viti (13).

👁 Note

I passatubi (P) vanno orientati verso il lato esterno dello stelo camicia forcelle.

Inserire n.2 rosette (12) fra il gruppo supporto connettori (K) e la testa di sterzo (R) in corrispondenza delle forature; avvitare e serrare le n.2 viti (13) alla coppia indicata.

Kit installation

● Caution

Check that all components are clean and in perfect condition before installation.
Adopt any precaution necessary to avoid damages to any part of the motorcycle you are working on.

Start and tighten no. 2 screws (11) to the specified torque.
Position headlight fairing support bracket (5) and start no. 2 screws (9) without tightening them.
Screw no. 2 original threaded pins (O) onto the headlight support (H3) putting the bracket (5) in-between.
Tighten no. 2 threaded pins (O) and no. 2 screws (9) to the specified torque.

Insert the n.2 hose grommets (P) and the no.2 washers (N) into the no.2 screws (13).

👁 Notes

Hose grommets (P) shall be positioned towards the outer side of fork jacket leg.

Fit no. 2 washers (12) between connector support unit (K) and steering head (R) into the holes; screw and tighten no. 2 screws (13) to the specified torque.

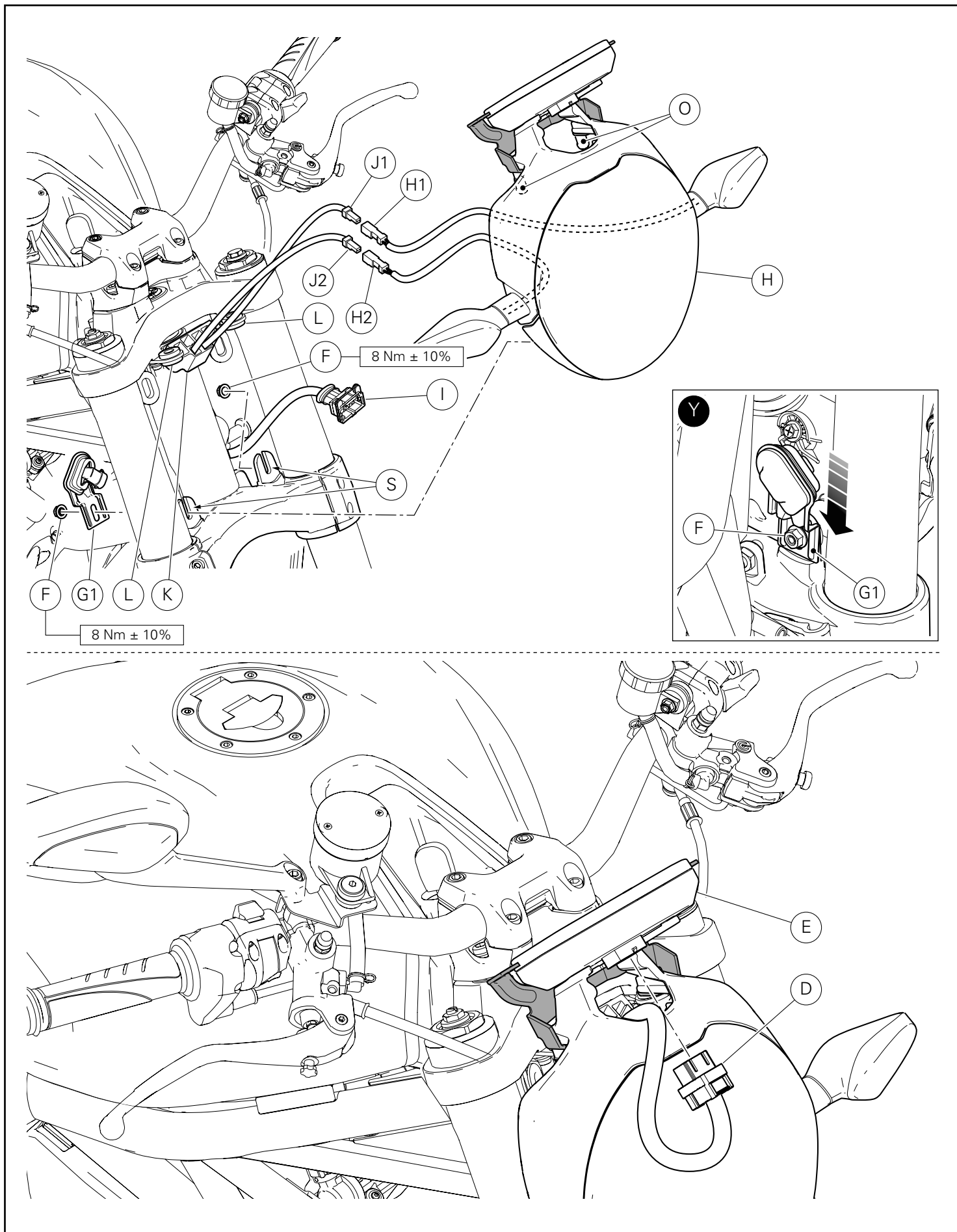

Collegare le prese (H1) e (H2) degli indicatori di direzione dalle rispettive spine (J1) e (J2) del cablaggio principale.

Inserire il collegamento degli indicatori di direzione nel supporto connettori (K).

Posizionare il gruppo fanale anteriore (H) con i perni filettati (O) in corrispondenza dei gommini antivibranti (L) e spingere verso il basso per incastrarlo.

Collegare la spina (I) sulla rispettiva presa presente sul gruppo fanale anteriore (H).

Posizionare i due antivibranti inferiori fissati al fanale anteriore con il filetto all'interno delle sedi (S) presenti sulla base di sterzo.

Inserire il supporto sensore temperatura aria (G1) sul filetto dell'antivibrante destro e impuntare i n.2 dadi originali (F).



Note

Durante il serraggio del dado (F) mantenere la staffa supporto sensore (G1) premuta verso il basso (a battuta sulla base di sterzo) per evitare che ruotando vada a contatto con lo stelo della forcella, come indicato in figura (Y).

Fissare il fanale anteriore (H) avvitando e serrando i n.2 dadi (F) alla coppia indicata

Collegare la connessione (D) al cruscotto (E).

Verifica

Controllare l'effettivo funzionamento dei dispositivi ottici anteriori:

- Indicatore di direzione sinistro
- Indicatore di direzione destro
- Luce posizione
- Luce abbagliante e anabbagliante

In caso di malfunzionamento verificare il corretto fissaggio delle prese con le spine e l'abbinamento giusto dei rami del cablaggio.

Connect turn indicator plugs (H1) and (H2) to their sockets (J1) and (J2) in the main wiring.

Fit the turn indicators connectors to connector mounting plate (K). Secure the headlight assembly (H) with threaded pins (O) to the vibration dampers (L) and push downwards to engage it.

Disconnect the plug (I) from its socket on the headlight assembly (H).

Secure the two lower vibration dampers to the headlight so that the thread fits into the seats (S) placed on the bottom yoke.

Insert the air temperature sensor support (G1) on the thread of the right vibration damper and start the no.2 original nuts (F).



Notes

When tightening nut (F), hold sensor support bracket (G1) pressed down (against bottom yoke) to prevent its rotation which could make it interfere with the fork leg, as shown in figure (Y).

Secure headlight (H) by screwing and tightening no. 2 nuts (F) to the specified torque.

Connect wiring connectors (D) to instrument panel (E).

Inspection

Ascertain that the front lights are functioning properly:

- Left turn indicator
- Right turn indicator
- Parking light
- Low and high beam

In case of malfunction, check the plugs and sockets are properly connected and that wiring connectors have been matched correctly.

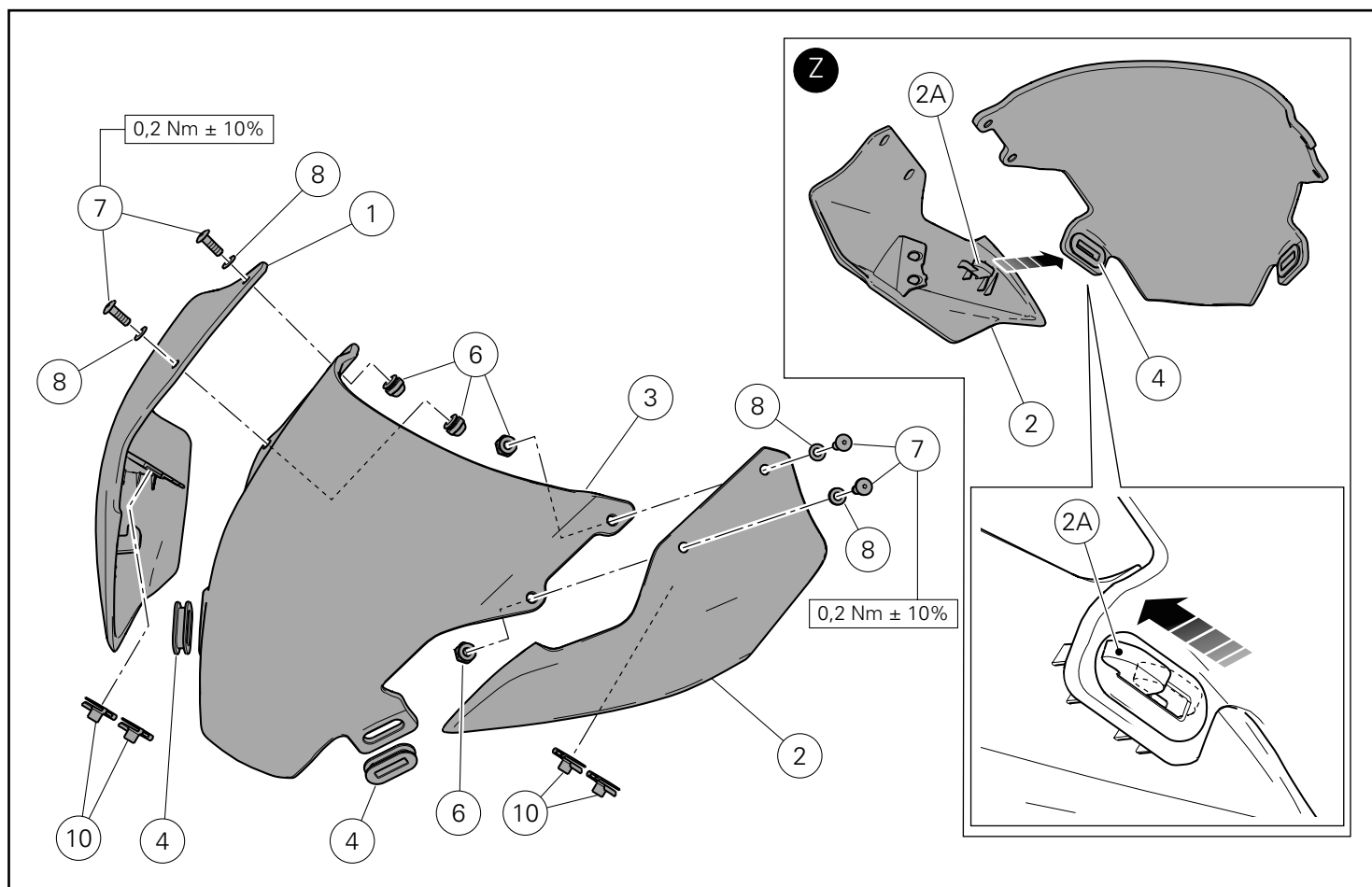

Premontaggio gruppo cupolino

Premontare le n.4 clips (10) sulla guancia cupolino destra (1) e sinistra (2).

Premontare i n.2 gommini (4) sul parabrezza (3).

Inserire il dente (2A) presente sulla guancia cupolino sinistra (2) nel gommino (4) appena montato e tirare indietro per incastrare la guancia sinistra (2) al parabrezza (3), come mostrato in figura (Z).

Inserire le n.2 rosette in nylon (8) sulle n.2 viti (7).

Impuntare, dalla parte esterna, le n.2 viti (7) e avvitare, dalla parte interna, i n.2 dadi elastici (6).

Serrare le n.2 viti (7) alla coppia indicata.

Ripetere la stessa operazione per il montaggio della guancia cupolino destra (1) sul parabrezza (3).

Headlight fairing unit pre-assembly

Pre-assemble no. 4 clips (10) on RH (1) and LH (2) headlight fairing panels.

Pre-assemble no. 2 rubber elements (4) on windscreen (3).

Fit retainer (2A) on LH headlight fairing panel (2) into rubber element (4) just assembled and pull backwards to engage LH panel (2) to windscreen (3), as shown in figure (Z).

Fit no. 2 nylon washers (8) on no. 2 screws (7).

Start no. 2 screws (7), from the outer part, and screw no. 2 spring nuts (6) from the inner part.

Tighten no. 2 screws (7) to the specified torque.

Repeat the same procedure to assemble RH headlight fairing panel (1) on windscreen (3).

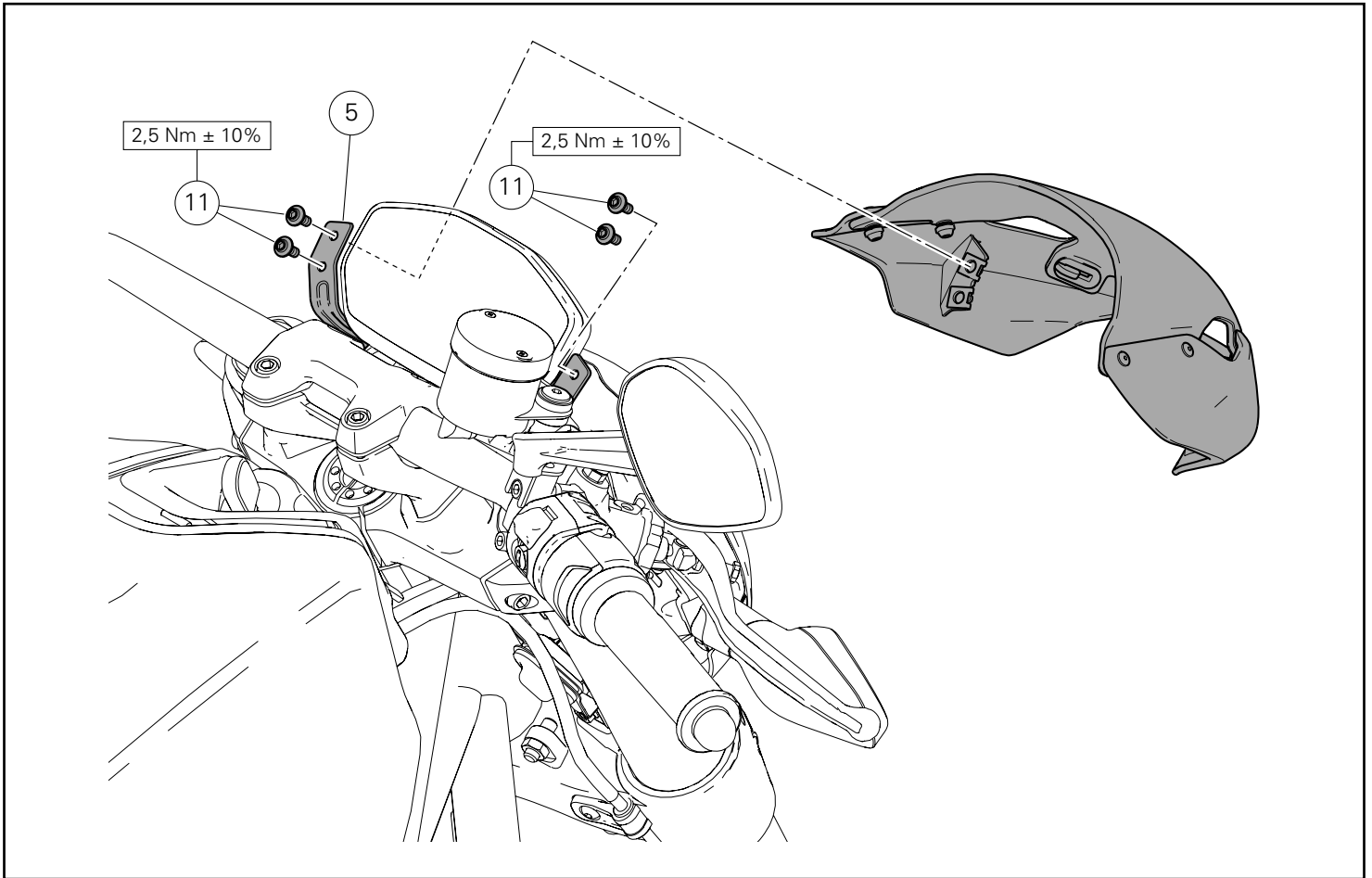

Posizionare il gruppo cupolino appena premontato sulla staffa (5) e impuntare le n.4 viti (11).
Serrare le n.4 viti (11) alla coppia indicata.

Position headlight fairing unit just pre-assembled on bracket (5) and start no. 4 screws (11).
Tighten no. 4 screws (11) to the specified torque.

Kit bulle Kit Cockpitverkleidung



Symboles

Pour faciliter la consultation de ce manuel, des symboles signalent des situations exigeant le maximum d'attention, des conseils pratiques ou de simples informations. Lire attentivement la signification de ces symboles car ils renvoient à des concepts techniques ou des consignes de sécurité de la plus grande importance. Ils doivent être considérés comme de véritables « aide-mémoire ». Toujours consulter cette page en cas de doute concernant leur signification.



Attention

La non-observance des instructions reportées ci-dessous peut créer une situation dangereuse et provoquer de graves lésions personnelles voire la mort.



Important

Indique la possibilité d'endommager le véhicule et/ou ses composants si les instructions reportées ci-dessous ne sont pas suivies.



Remarques

Fournit des informations utiles sur l'opération en cours.

Références

Les pièces surlignées en gris et la référence numérique (Ex. ①) représentent l'accessoire à installer et les composants de montage éventuels fournis en kit.

Les pièces avec référence alphabétique (Ex. Ⓐ) représentent les composants d'origine présents sur le motorcycle.

Toutes les indications droite ou gauche se réfèrent au sens de marche la moto.

Avertissements généraux



Attention

Les opérations indiquées dans les pages suivantes, au cas où elles ne seraient pas effectuées selon les règles de l'art pourraient compromettre la sécurité du pilote.



Attention

Les opérations indiquées dans les pages suivantes, au cas où elles ne seraient pas effectuées selon les règles de l'art pourraient compromettre la sécurité du pilote.



Remarques

La documentation nécessaire pour effectuer la pose du Kit est le : MANUEL D'ATELIER, relatif au modèle de moto en votre possession.



Remarques

Au cas où il serait nécessaire d'effectuer le remplacement d'un composant du kit, il faudra consulter la planche relative aux pièces détachées ci-jointe.

Symbole

Zum schnellen und übersichtlichen Lesen werden Symbole verwendet, die außerordentlich wichtige Situationen, praktische Ratschläge oder auch nur einfache Informationen hervorheben. Der Bedeutung dieser Symbole ist besondere Aufmerksamkeit zu schenken, da sich hierdurch das ständige Wiederholen von technischen Konzepten oder Sicherheitshinweisen erübrigt. Sie stellen daher regelrechte „Merker“ dar. Diese Seite ist immer dann zur Hand zu nehmen, wenn Zweifel über die Bedeutung eines Symbols bestehen sollten.



Achtung

Eine Nichtbeachtung der hier wiedergegebenen Anweisungen kann Gefahrensituationen schaffen und zu schweren Verletzungen und auch zum Tod führen.



Wichtig

Weist darauf hin, dass bei Nichteinhaltung der hier wiedergegebenen Anweisungen die Möglichkeit für Schäden am Fahrzeug und/oder seiner Komponenten besteht.



Hinweis

Übermittelt nützliche Informationen zum betreffenden Arbeitseingriff.

Bezugsangaben

Die grau gekennzeichneten Bestandteile mit numerischem Bezug (Bsp. ①) geben das zu installierende Bestandteil und die eventuellen, im Kit enthaltenen Montagekomponenten wieder.

Die Bestandteile mit alphabetischem Bezug (Bsp. Ⓐ) geben die Original-Bestandteile wieder, die am Motorrad verbaut wurden.

Alle Angaben wie „rechts“ oder „links“ beziehen sich auf die Fahrtrichtung des Motorrads.

Allgemeine Warnhinweise



Achtung

Werden die auf den folgenden Seiten beschriebenen Arbeitsmaßnahmen nicht fachgerecht ausgeführt, kann sich dies auf die Sicherheit des Fahrers auswirken.



Achtung

Werden die auf den folgenden Seiten beschriebenen Arbeitsmaßnahmen nicht fachgerecht ausgeführt, kann sich dies auf die Sicherheit des Fahrers auswirken.



Hinweis

Für die Montage des Kits sind folgende Unterlagen erforderlich: WERKSTATTHANDBUCH, des sich in Ihrem Besitz befindlichen Motorrads.



Hinweis

Sollte sich der Austausch eines Bestandteils des Kits als erforderlich erweisen, ist dazu Bezug auf die beiliegende Ersatzteilliste zu nehmen.

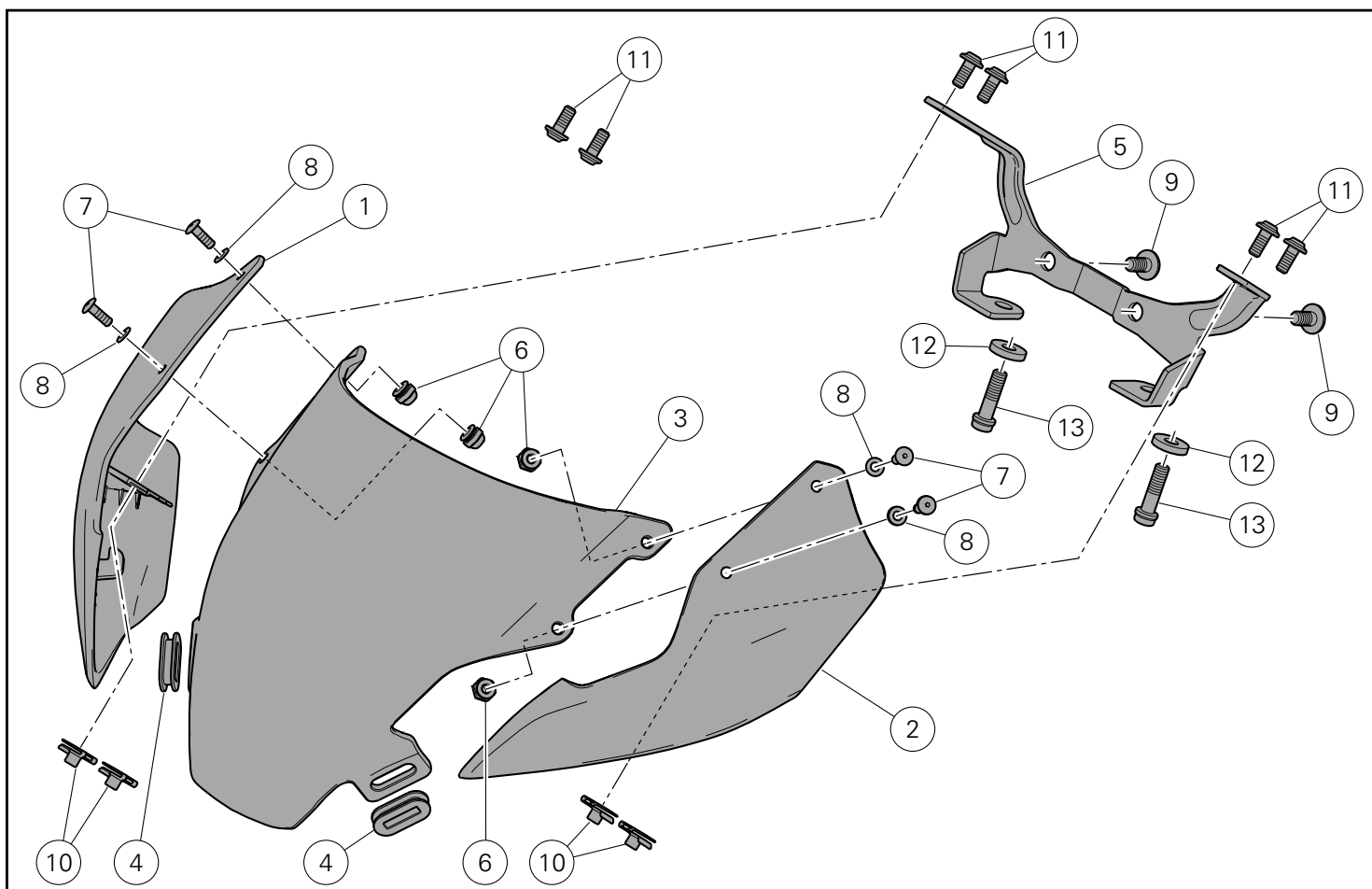

Pos.	Designation	Bezeichnung
1	Joue bulle droite	Rechte Cockpitverkleidungsschale
2	Joue bulle gauche	Linke Cockpitverkleidungsschale
3	Pare-brise central	Mittlerer Fahrtwindschutz
4	Plot caoutchouc	Gummielement
5	Bride de support bulle	Stützbügel für Cockpitverkleidung
6	Écrou élastique	Elastische Mutter
7	Vis spéciale TB M4x12	Spezialschraube TB M4x12
8	Rondelle en nylon	Unterlegscheibe aus Nylon
9	Vis TBHCF M6x12	Linseninnensechskantschraube M6x12
10	Clip	Clip
11	Vis TBHC M5x12	Linseninnensechskantschraube M5x12
12	Rondelle	Unterlegscheibe
13	Vis TCHCF M6x22	Geflanschte Innensechskantschraube M6x22

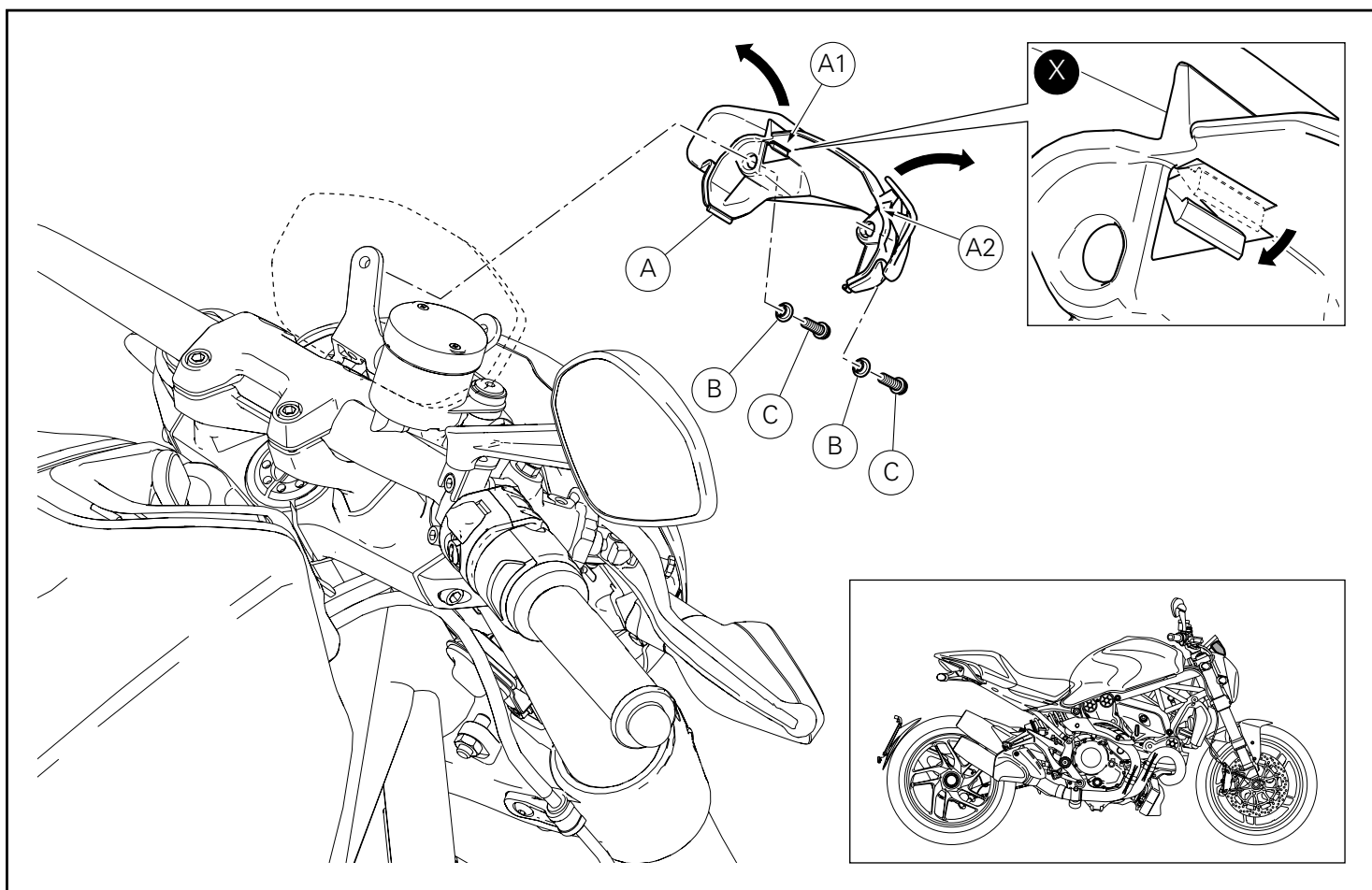

Dépose composants d'origine

Remarques

La procédure d'installation du kit est la même pour tous les motocycles Monster 1200 et Monster 821, c'est pourquoi on utilise comme exemple la procédure à adopter sur le modèle Monster 1200.

Ouvrir les deux ailettes du cover tableau de bord (A) en décrochant les deux ergots (A1) et (A2), comme indiqué dans la figure (X). Desserrer les 2 vis (C) et déposer les 2 entretoises (B) et le cover tableau de bord (A).

Ausbau der Original-Bestandteile

Hinweis

Das bei diesem Kit anzuwendende Montageverfahren trifft auf alle Motorräder Monster 1200 und Monster 821 zu. Daher wurde im Beispiel die Monster1200 verwendet.

Die beiden Rippen der Cockpitabdeckung (A) durch Lösen der beiden Zähne (A1) und (A2) der Abbildung (X) gemäß öffnen. Die 2 Schrauben (C) lösen, dann die 2 Distanzstücke (B) und die Cockpitabdeckung (A) entfernen.

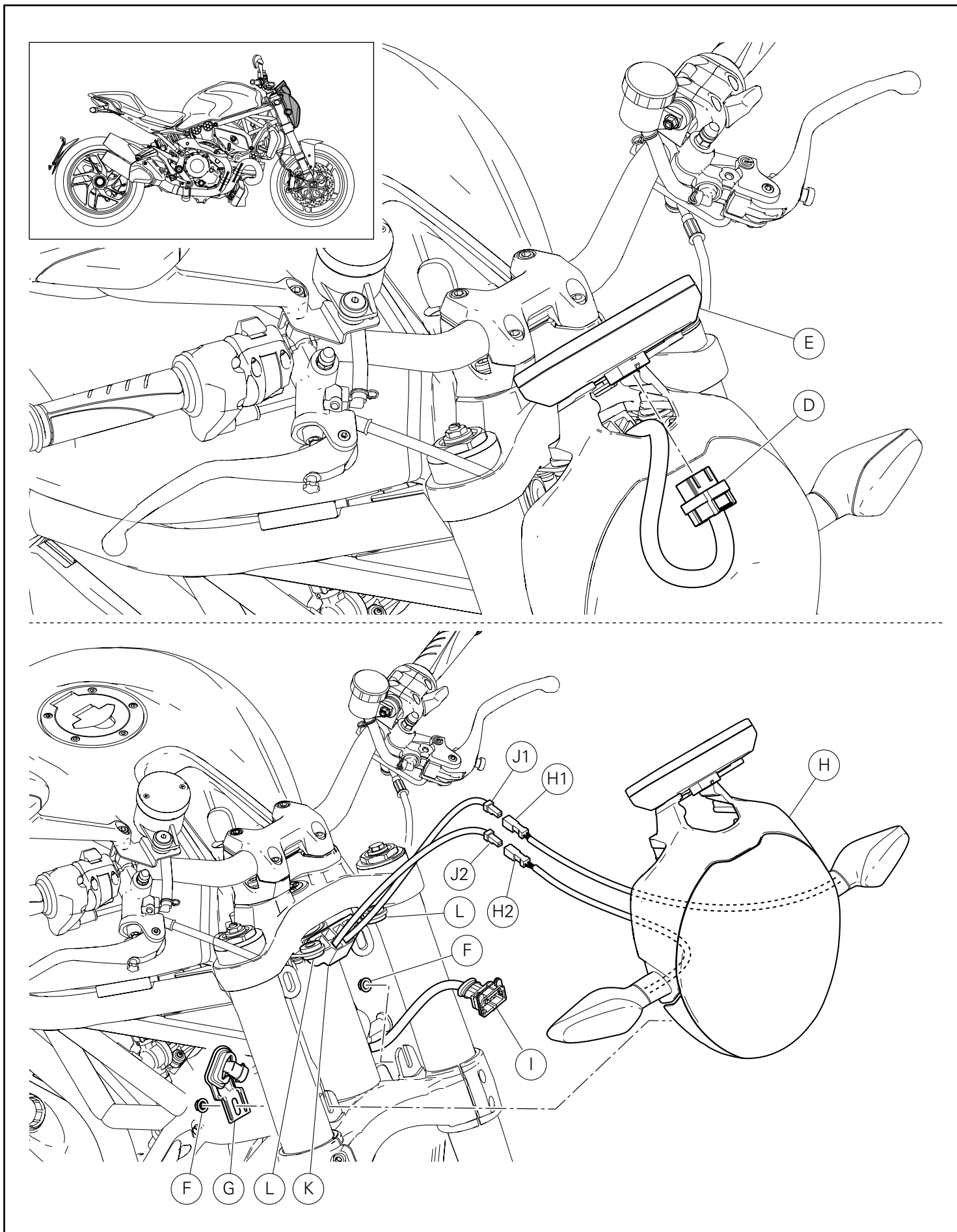

Débrancher le connecteur (D) du tableau de bord (E).

Desserrer les 2 écrous (F).



Important

En cours de dépose de l'écrou droit, prendre garde de ne pas endommager le capteur de température air (G) en le supportant adéquatement.

Débrancher la fiche (I) de la prise correspondante présente sur l'ensemble phare avant (H).

Déposer l'ensemble phare avant (H) en le décrochant des plots antivibratoires (L).

Sortir les connecteurs des clignotants du support connecteurs (K).

Débrancher les prises (H1) et (H2) des clignotants des fiches correspondantes (J1) et (J2) du câblage principal.

Die Verbindung (D) vom Cockpit (E) trennen.

Die 2 Muttern (F) lösen.



Wichtig

In der Ausbauphase der rechten Mutter darauf achten, dass der Lufttemperatursensor (G) nicht beschädigt wird und ihn in angemessener Weise abstützen.

Den Stecker (I) aus dem entsprechenden Anschluss des Scheinwerfers (H) ziehen.

Die Scheinwerfereinheit (H) durch Aushaken aus den Schwingungdämpfergummis (L) entfernen.

Die Verbindung der Blinker vom Halter der Verbinder (K) abziehen.

Die Stecker (J1) und (J2) des Hauptkabelbaums von den Anschlüssen (H1) und (H2) der Blinker trennen.

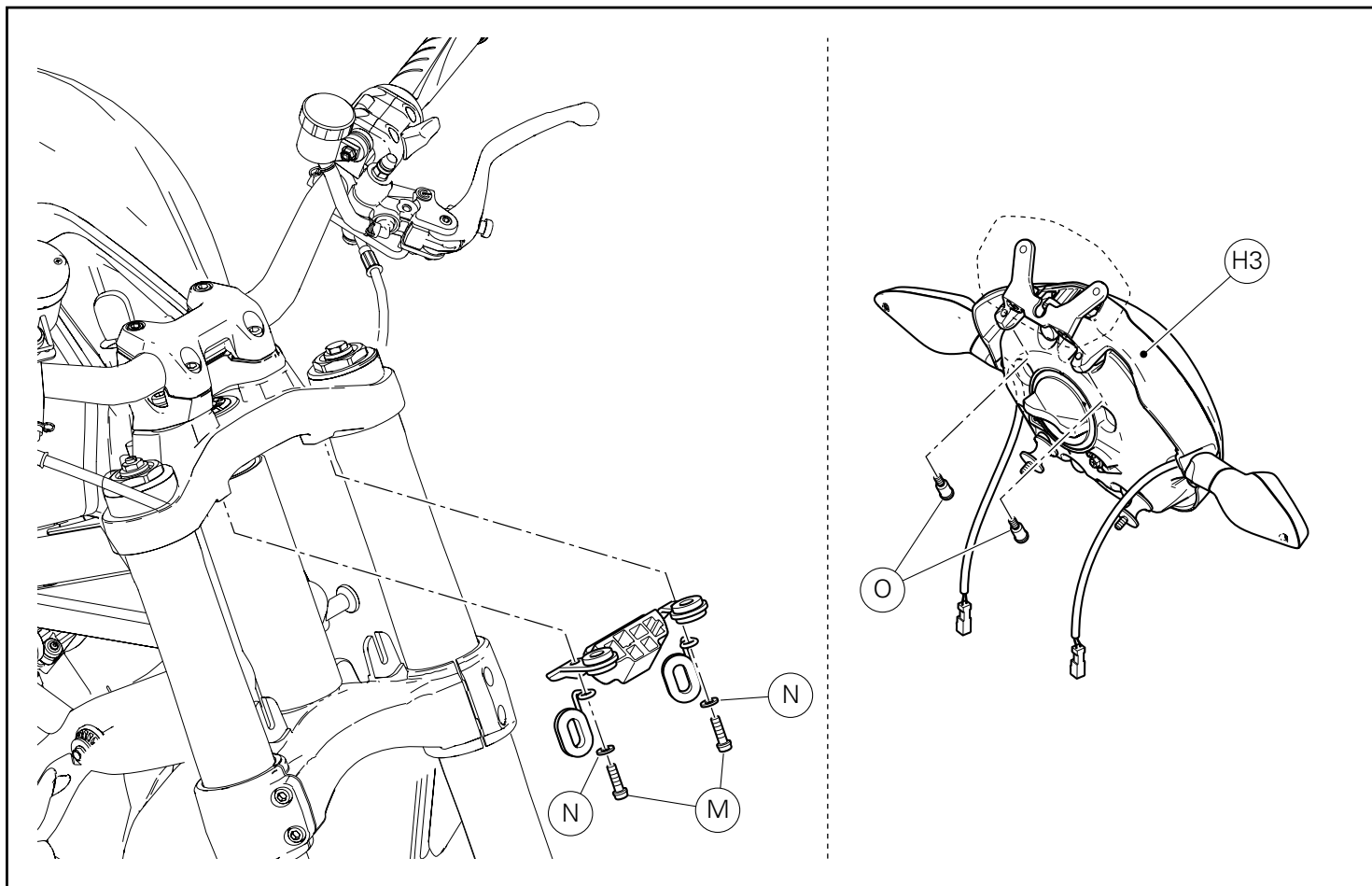

Desserrer les 2 vis (M) et les 2 rondelles (N).
Récupérer les 2 rondelles (N).

Libérer les 2 axes filetés (O) du support de phare (H3).

Die 2 Schrauben (M) und die 2 Unterlegscheiben (N) lösen.
Die 2 Unterlegscheiben (N) aufnehmen.

Die 2 Gewindestifte (O) aus dem Scheinwerferhalter (H3) lösen.

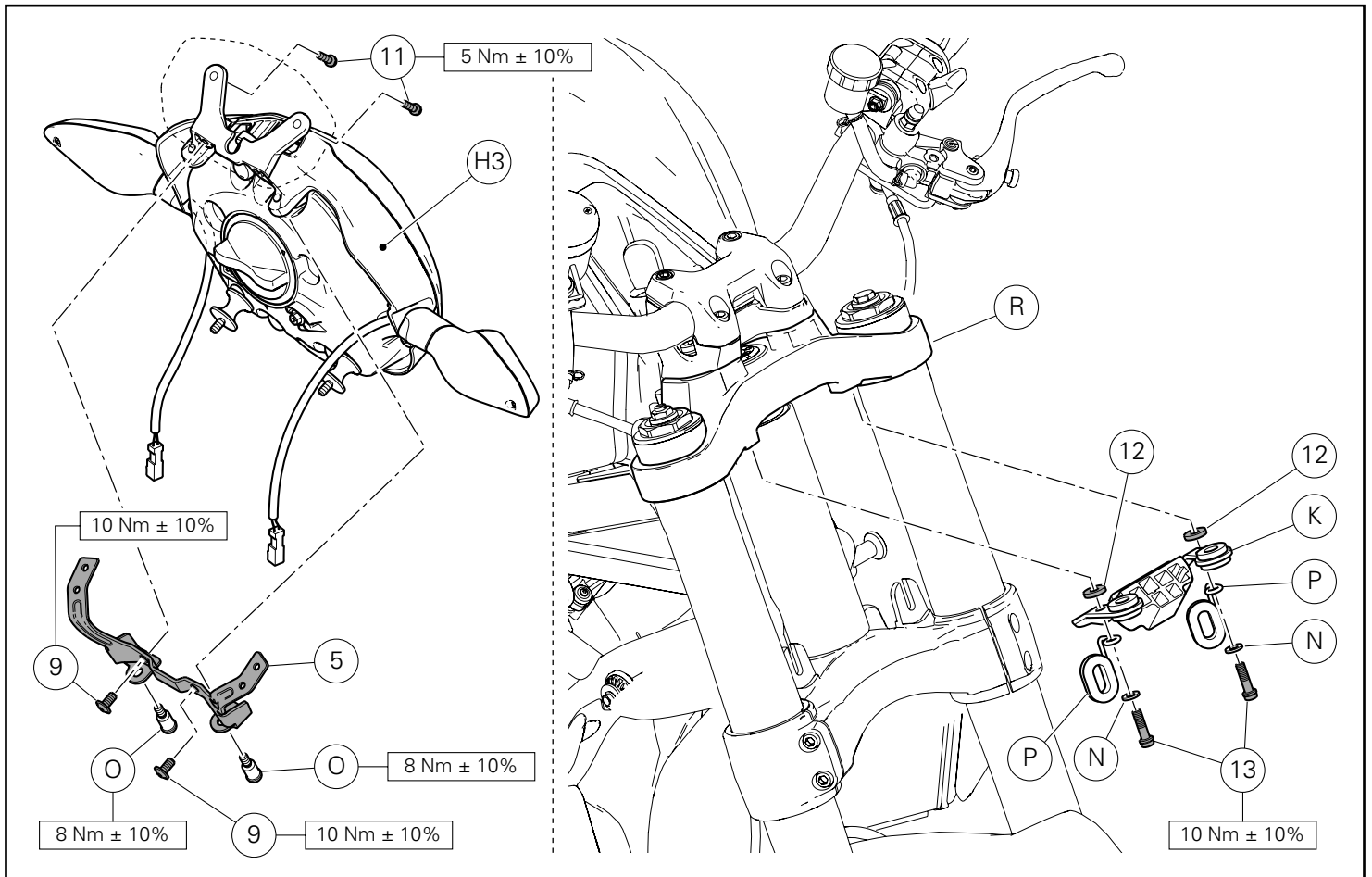

Pose composants kit



Important

Vérifier, avant la pose, que tous les composants sont propres et en parfait état.

Adopter toutes les précautions nécessaires pour éviter d'endommager la surface externe des composants où on opère.

Présenter et serrer les 2 vis (11) au couple prescrit.

Positionner la bride de support bulle (5), puis présenter les 2 vis (9) sans les serrer.

Visser les 2 axes filetés d'origine (O) sur le support de phare (H3) en interposant la bride (5).

Serrer les 2 axes filetés (O) et les 2 vis (9) au couple prescrit.

Insérer les 2 passe-tuyaux (P) et les 2 rondelles (N) dans les 2 vis (13).



Remarques

Les passe-tuyaux (P) sont à orienter vers le côté extérieur du tube fourreau de fourches.

Insérer les deux rondelles (12) entre le groupe support connecteurs (K) et le té supérieur (R) au niveau des trous ; visser et serrer les 2 vis (13) au couple prescrit.

Montage der Komponenten des Kits



Wichtig

Vor der Montage überprüfen, dass sich alle Komponenten im sauberen und perfekten Zustand befinden.

Alle erforderlichen Vorsichtsmaßnahmen treffen, um eine Beschädigung der Oberflächen der Komponenten, die vom Eingriff betroffen sind, zu vermeiden.

Die 2 Schrauben (11) ansetzen und mit dem angegebenen Anzugsmoment anziehen.

Den Stützbügel für Cockpitverkleidung (5) anordnen und die 2 Schrauben (9) ansetzen, ohne sie anzuziehen.

Die 2 Original-Gewindestifte (O) am Scheinwerferhalter (H3) nach Zwischensetzen des Bügels (5) anschrauben.

Die 2 Gewindestifte (O) und die 2 Schrauben (9) mit dem angegebenen Anzugsmoment anziehen.

Die 2 Leitungsführungen (P) und die 2 Unterlegscheiben (N) an die 2 Schrauben (13) anfügen.



Hinweis

Die Leitungsführungen (P) müssen zur Außenseite des Gabelholms gerichtet werden.

Die 2 Unterlegscheiben (12) an den Bohrungen zwischen die Steckerhaltereinheit (K) und die obere Gabelbrücke (R) fügen. Die 2 Schrauben (13) anschrauben und mit dem angegebenen Anzugsmoment anziehen.

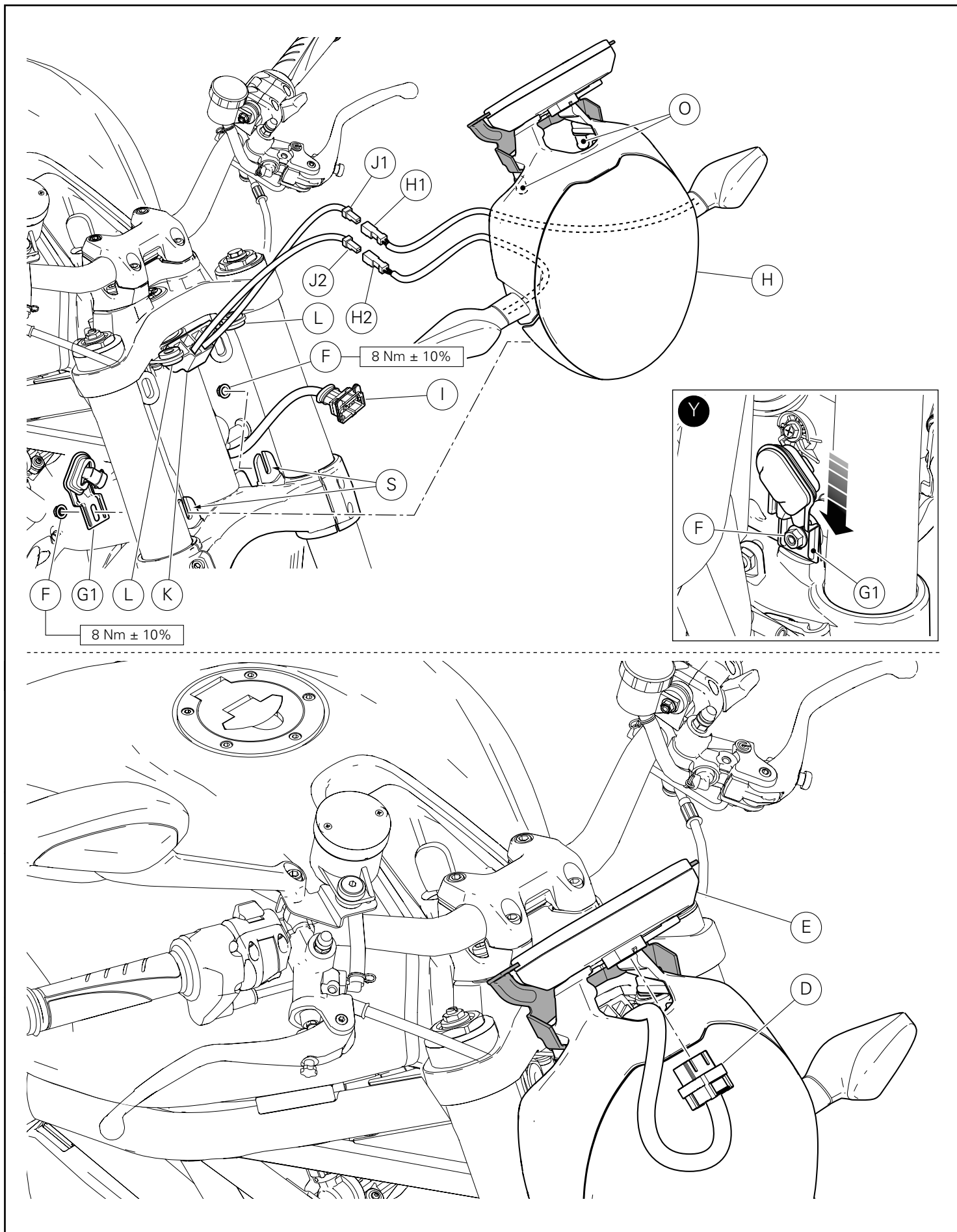

Relier les prises (H1) et (H2) des clignotants aux fiches correspondantes (J1) et (J2) du câblage principal.
Insérer les connecteurs des clignotants dans le support connecteurs (K).

Positionner l'ensemble phare avant (H) avec les axes filetés (O) au niveau des plots antivibratoires (L) et pousser vers le bas pour l'encaster.

Relier la fiche (I) à la prise correspondante présente sur l'ensemble phare avant (H).

Positionner les deux plots antivibratoires inférieurs fixés au phare avant, avec le filet à l'intérieur des logements (S) présents sur le té inférieur.

Insérer le support capteur de température air (G1) sur le filet du plot antivibratoire droit et présenter les 2 écrous d'origine (F).



Remarques

Pendant le serrage de l'écrou (F) maintenir la bride de support capteur (G1) appuyée vers le bas (en butée sur le té inférieur) pour éviter que, en tournant, elle entre en contact avec le tube de fourche, comme la figure (Y) le montre.

Fixer le phare avant (H) en vissant et serrant les 2 écrous (F) au couple prescrit.

Relier le connecteur (D) au tableau de bord (E).

Contrôle

Contrôler le fonctionnement effectif des dispositifs optiques avant:

- clignotant gauche ;
- clignotant droit ;
- feu de position ;
- feu de route et feu de croisement.

En cas de dysfonctionnement, vérifier que les prises et les fiches sont bien fixées et que les brins du câblage sont bien agencés.

Die Stecker (J1) und (J2) des Hauptkabelbaums an den Anschlüssen (H1) und (H2) der Blinker anschließen.

Die Verbindung der Blinker am Halter der Verbinder (K) wieder herstellen.

Die Scheinwerfereinheit (H) mit den Gewindestiften (O) an den Schwingungsdämpfergummis (L) anordnen und nach unten drücken, um sie zum Einrasten zu bringen.

Den Stecker (I) am entsprechenden Anschluss des Scheinwerfers (H) anschließen.

Die beiden unteren, am Scheinwerfer befestigten Schwingungsdämpfer mit dem Gewinde in den Sitzen (S) an der unteren Gabelbrücke anordnen.

Die Lufttemperatursensoreinheit (G1) am Gewinde des rechten Schwingungsdämpfers anfügen und die 2 Original-Muttern (F) ansetzen.



Hinweis

Während dem Anzug der Mutter (F), den Sensorstützbügel (G1) nach unten gedrückt halten (auf Anschlag an der unteren Gabelbrücke), um zu vermeiden, dass er durch Drehen mit dem Gabelholm in Kontakt kommt, siehe Abbildung (Y).

Den Scheinwerfer (H) befestigen, dazu die 2 Muttern (F) einschrauben und mit dem angegebenen Anzugsmoment anziehen.

Die Verbindung (D) an das Cockpit (E) schließen.

Überprüfung

Die effektive Funktionstüchtigkeit der vorderen Lichter kontrollieren:

- Linker Blinker
- Rechter Blinker
- Standlicht
- Fern- und Abblendlicht

Bei Funktionsstörungen ist die korrekte Kopplung der Stecker in den Anschlüssen sowie die korrekte Passung der Verkabelungszweige zu überprüfen.

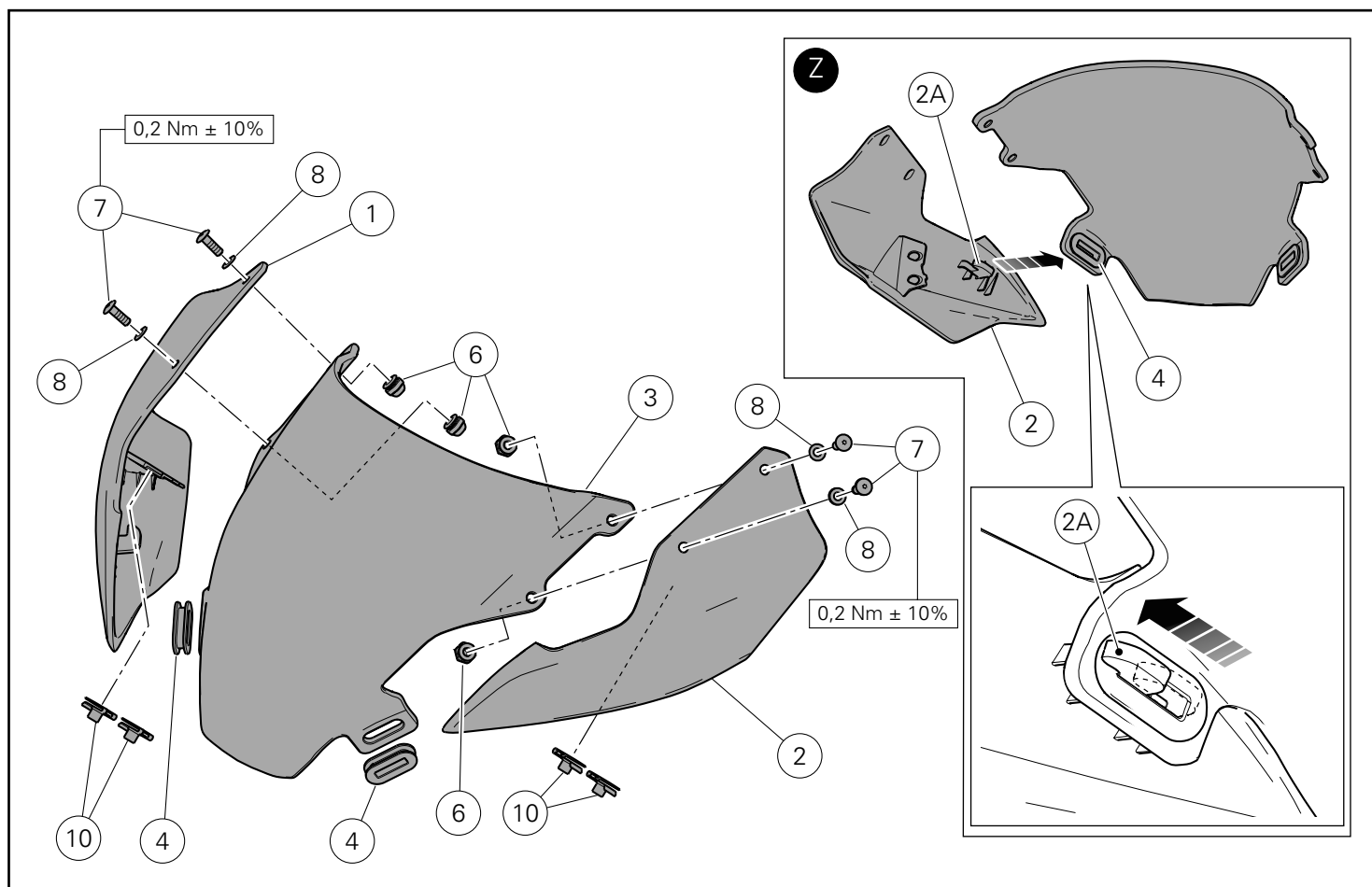

Pré-montage ensemble bulle

Pré-monter les 4 clips (10) sur la joue bulle droite (1) et gauche (2).
Monter les 2 plots caoutchouc (4) sur le pare-brise (3).

Insérer la dent (2A) présente sur la joue bulle gauche (2) dans le plot caoutchouc (4) qu'on vient de monter et tirer en arrière pour encastrement la joue gauche (2) au pare-brise (3), comme la figure (Z) le montre.

Insérer les 2 rondelles en nylon (8) sur les 2 vis (7).

Présenter les 2 vis (7) du côté extérieur et visser les 2 écrous élastiques (6) du côté intérieur.

Serrer les 2 vis (7) au couple prescrit.

Répéter la même opération pour le montage de la joue bulle droite (1) sur le pare-brise (3).

Vormontage der Cockpitverkleidungsgruppe

Die 4 Clips (10) auf der rechten (1) und linken (2) Cockpitverkleidungsschale vormontieren.
Die 2 Gummielemente (4) am Fahrtwindschutz (3) vormontieren.

Den Zahn (2A) der linken Cockpitverkleidungsschale (2) in das eben montierte Gummielement (4) einfügen und nach hinten ziehen, um die linke Schale (2) am Fahrtwindschutz (3) gemäß Abbildung (Z) einzuspannen.

Die 2 Nylon-Unterlegscheiben (8) an den 2 Schrauben (7) ansetzen.
Von der Außenseite her, die 2 Schrauben (7) ansetzen und, von der Innenseite her, die 2 elastischen Muttern (6) anschrauben.
Die 2 Schrauben (7) mit dem angegebenen Anzugsmoment anziehen.

Das Verfahren für die Montage der rechten Cockpitverkleidungsschale (1) am Fahrtwindschutz (3) wiederholen.

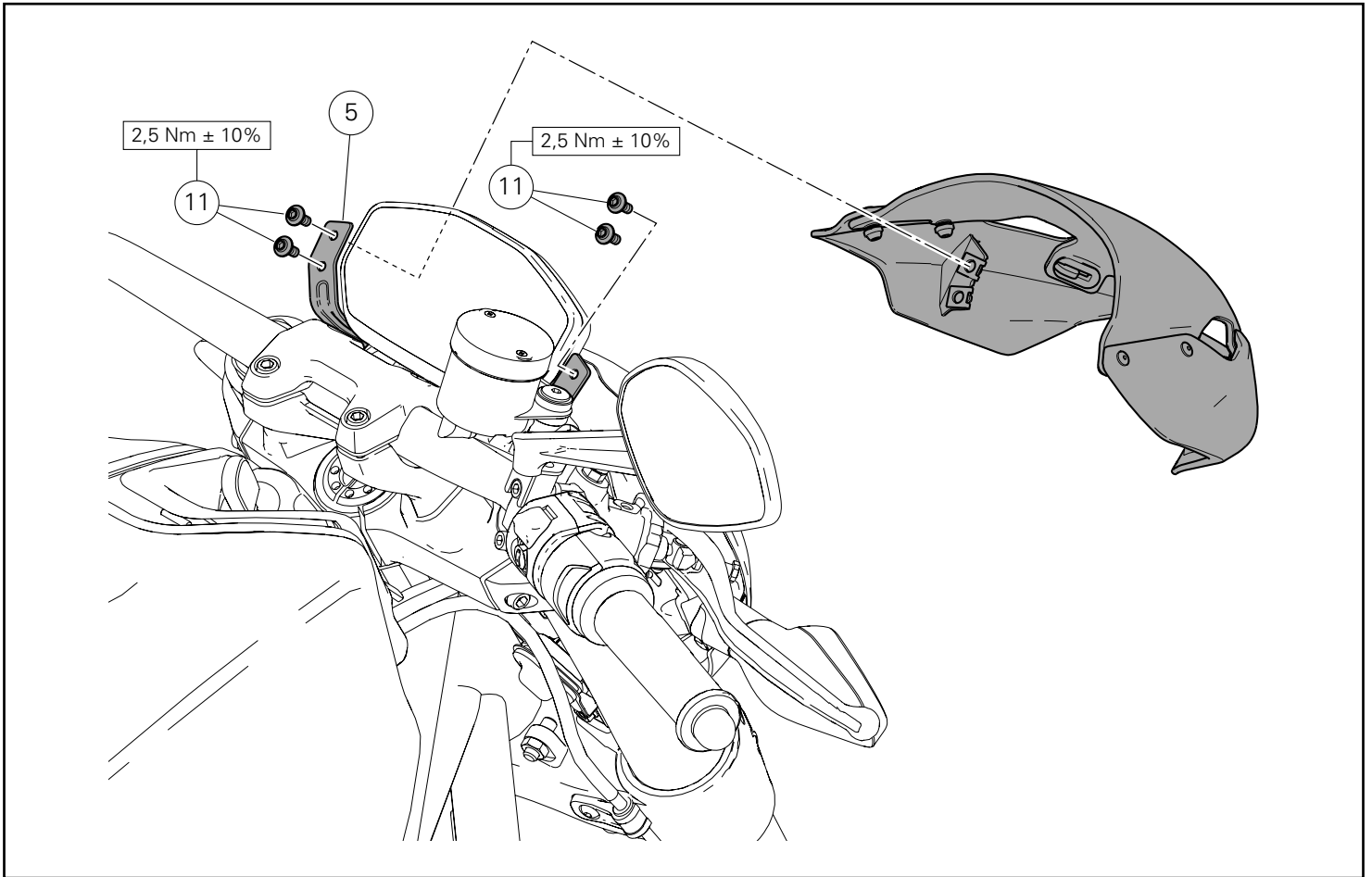

Positionner l'ensemble bulle qu'on vient de pré-monter sur la bride (5) et présenter les 4 vis (11).
Serrer les 4 vis (11) au couple prescrit.

Die eben vormontierte Cockpitverkleidungsgruppe am Bügel (5) anordnen und die 4 Schrauben (11) ansetzen.
Die 4 Schrauben (11) mit dem angegebenen Anzugsmoment anziehen.

REMARQUES / HINWEIS

Handwriting practice area consisting of 20 horizontal dotted lines.

Conjunto cúpula Headlight fairing kit



Símbolos

Para uma leitura rápida e racional, foram utilizados símbolos que evidenciam situações de máxima atenção, conselhos práticos ou simples informações. Preste muita atenção ao significado dos símbolos, pois a sua função é a de evitar a repetição de conceitos técnicos ou de avisos de segurança. Portanto, os símbolos devem ser considerados como verdadeiros "lembretes". Consulte esta página sempre que tiver dúvidas acerca do seu significado.



Atenção

O não cumprimento das instruções mostradas pode criar uma situação de perigo e causar graves lesões pessoais e até mesmo a morte.



Importante

Indica a possibilidade de causar danos ao veículo e/ou aos seus componentes se as instruções mostradas não forem executadas.



Notas

Fornisce utili informazioni sull'operazione in corso.

Referências

Os detalhes evidenciados em cinza e com referência numérica (Ex. ①) representam o acessório a ser instalado e os eventuais componentes de montagem fornecidos como kit.

Os detalhes com referência alfabética (Ex. A) representam os componentes originais presentes na moto.

Todas as indicações direita ou esquerda, referem-se ao sentido de marcha da moto.

Advertências gerais



Atenção

As operações mostradas nas páginas a seguir, se não forem executadas com boa técnica, podem prejudicar a segurança do condutor.



Atenção

As operações mostradas nas páginas a seguir, se não forem executadas com boa técnica, podem prejudicar a segurança do condutor.



Notas

Documentação necessária para executar a montagem do Conjunto: MANUAL DE OFICINA, relativo ao modelo de moto em sua posse.



Notas

Caso seja necessária a substituição de um componente do conjunto, consulte o quadro de peças de reposição em anexo.

Symbols

To allow quick and easy consultation, this manual uses graphic symbols to highlight situations in which maximum care is required, as well as practical advice or information.

Pay attention to the meaning of the symbols since they serve to avoid repeating technical concepts or safety warnings throughout the text. The symbols should therefore be seen as real reminders. Please refer to this page whenever in doubt as to their meaning.



Warning

Failure to follow these instructions might give raise to a dangerous situation and provoke severe personal injuries or even death.



Caution

Failure to follow these instructions might cause damages to the vehicle and/or its components.



Notes

Useful information on the procedure being described.

References

Parts highlighted in grey and with a numeric reference (Example ①) are the accessory to be installed and any assembly components supplied with the kit.

Parts with an alphabetic reference (Example A) are the original components fitted on the vehicle.

Any right- or left-hand indication refers to the vehicle direction of travel.

General notes



Warning

Carefully perform the operations on the following pages since they might negatively affect rider safety.



Warning

Carefully perform the operations on the following pages since they might negatively affect rider safety.



Notes

The following documents are necessary for assembling the Kit: WORKSHOP MANUAL of your bike model.



Notes

Should it be necessary to change any kit parts, please refer to the attached spare part table.

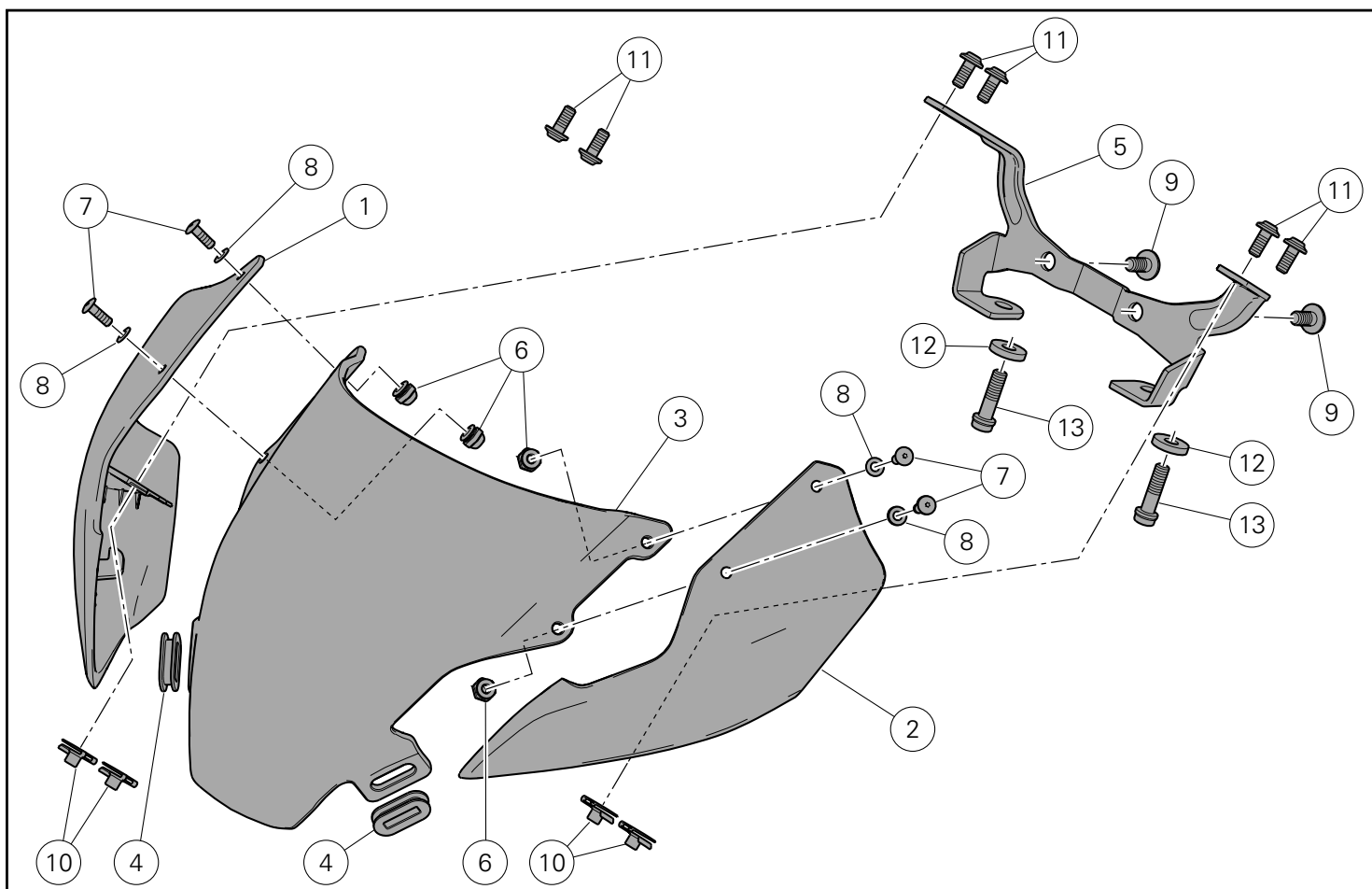

Pos.	Descrição	Description
1	Face direita da cúpula	RH headlight fairing panel
2	Face esquerda da cúpula	LH headlight fairing panel
3	Para-brisas central	Central windscreen
4	Anel de borracha	Rubber block
5	Grampo de suporte da cúpula	Headlight fairing support bracket
6	Porca elástica	Spring nut
7	Parafuso especial de cabeça abaulada M4x12	TB special screw M4x12
8	Anilha de nylon	Nylon washer
9	Parafuso de cabeça abaulada flangeada com sextavado interno M6x12	TBEIF screw M6x12
10	Clip	Clip
11	Parafuso de cabeça abaulada com sextavado interno M5x12	TBEI screw M5x12
12	Anilha	Washer
13	Parafuso de cabeça cilíndrica flangeada com sextavado interno M6x22	TCEIF screw M6x22

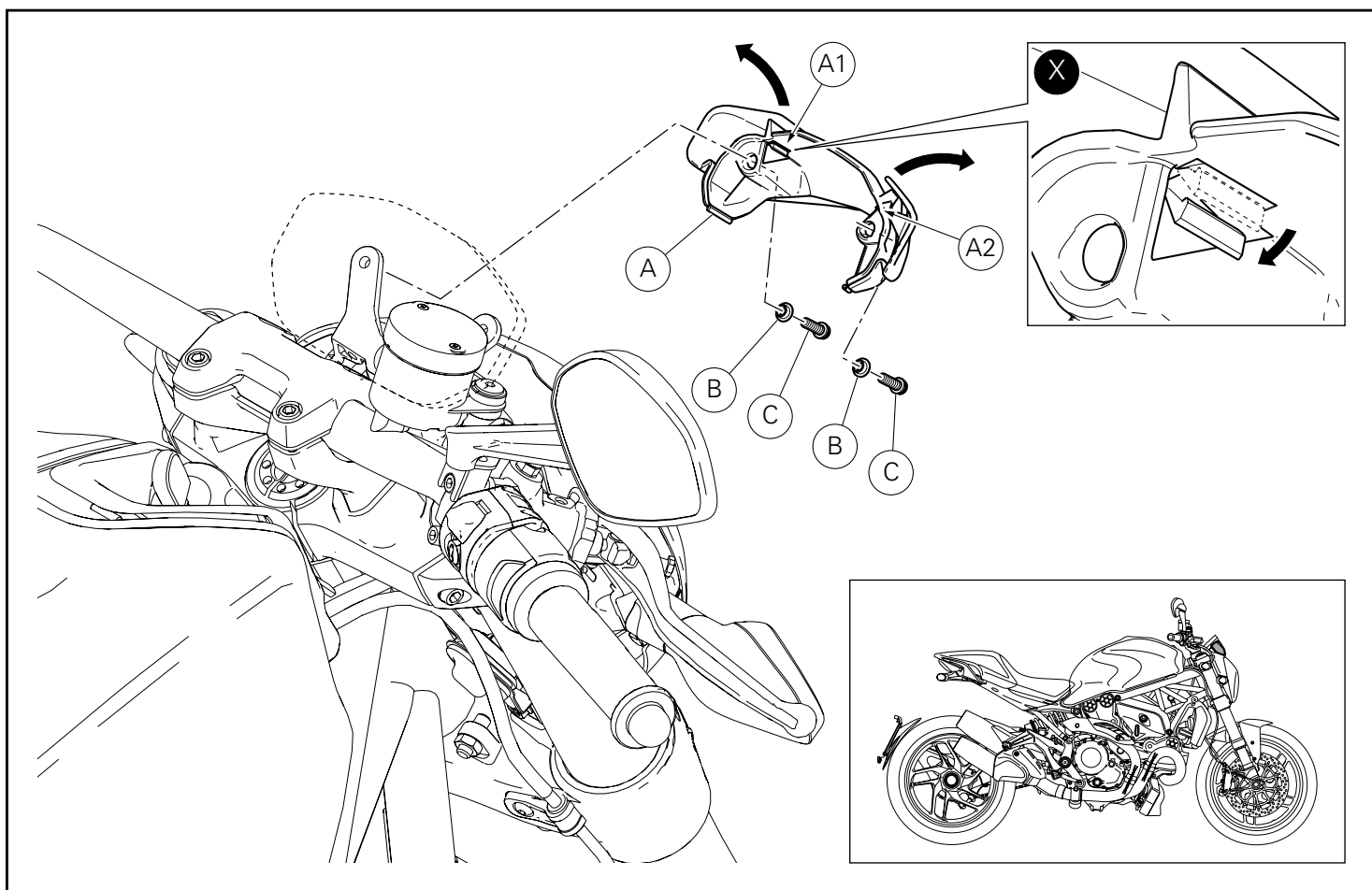

Desmontagem dos componentes originais

Notas

O procedimento de montagem do conjunto é o mesmo para todas as motos Monster 1200 e Monster 821, para as quais é utilizado, como exemplo, o procedimento a adotar no modelo Monster1200.

Abra as duas aletas da cobertura do painel de instrumentos (A), desengatando os dois dentes (A1) e (A2), como o indicado na figura (X).

Desatarraxe os 2 parafusos (C) e remova os 2 espaçadores (B) e a cobertura do painel de instrumentos (A).

Removing the original components

Notes

The kit installing procedure is the same for all 1200 and Monster 821 motorcycles. The procedure for Monster 1200 will be described here as a general example.

Open the two tabs of instrument panel cover (A) by disengaging the two teeth (A1) and (A2), as shown in figure (X).

Release the n.2 screws (C) and remove the n.2 spacers (B) and the instrument panel cover (A).

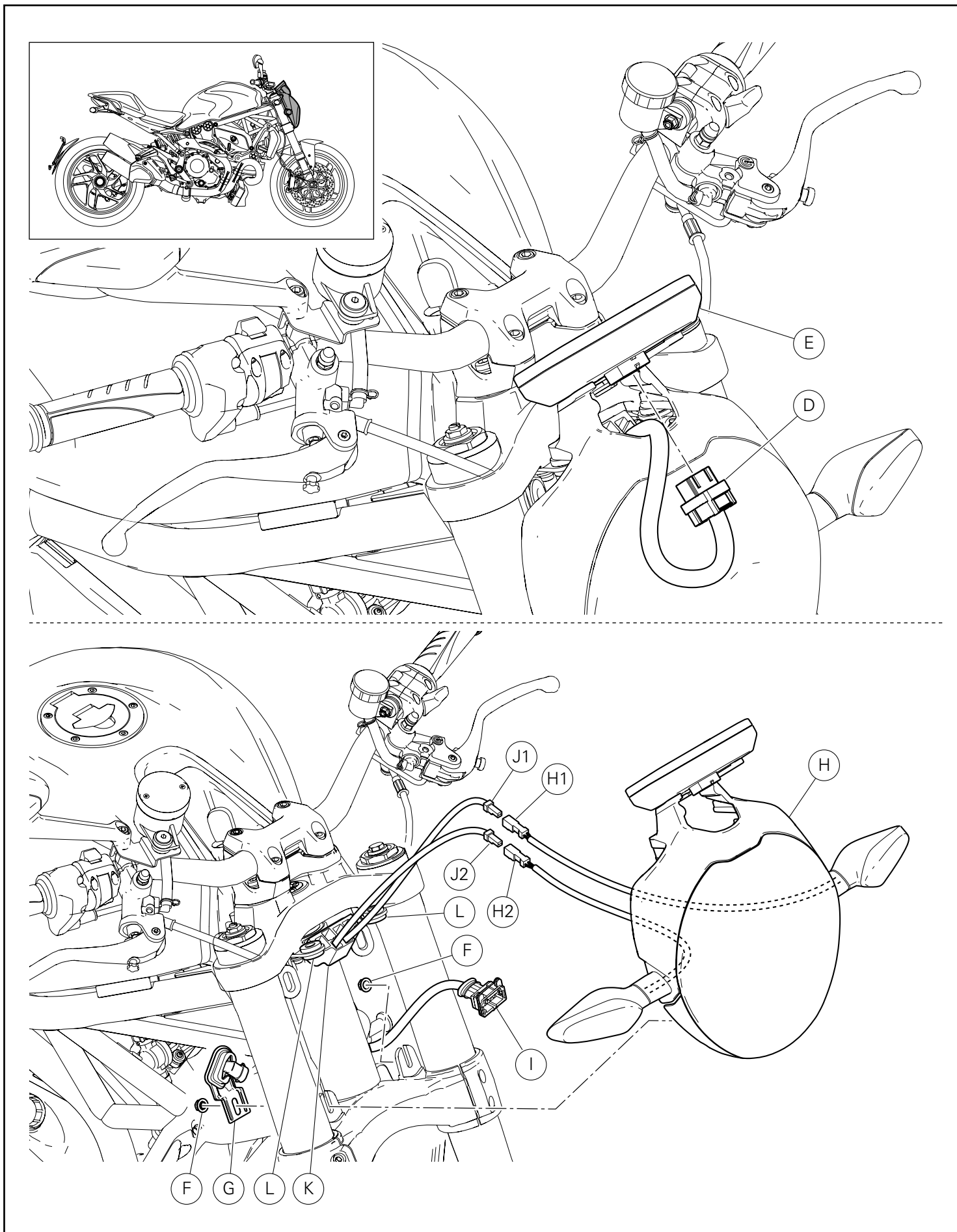

Desligue a conexão (D) pelo painel de instrumentos (E).

Desatarraxe as 2 porcas (F).



Importante

Durante a fase de desmontagem da porca direita, preste atenção para não danificar o sensor de temperatura do ar (G), suportando-o adequadamente.

Desligue a ficha (I) da respetiva tomada existente no grupo do farol dianteiro (H).

Remova o grupo do farol dianteiro (H), desengatando-o pelos anéis de borracha anti-vibrações (L).

Extraia a ligação dos indicadores de direção pelo suporte dos conectores (K).

Desligue as tomadas (H1) e (H2) dos indicadores de direção pelas respetivas fichas (J1) e (J2) da cablagem principal.

Disconnect wiring connectors (D) from instrument panel (E).

Loosen n.2 nuts (F).



Caution

While releasing the right nut, make sure that the air temperature sensor (G) is not damaged, and properly support it.

Disconnect the plug (I) from its socket on the front light assembly (H).

Remove headlight assembly (H) by disconnecting it from vibration damper rubber blocks (L).

Remove the turn indicators connectors from connector mounting plate (K).

Disconnect turn indicator plug (H1) and (H2) from their sockets (J1) and (J2) in the main wiring.

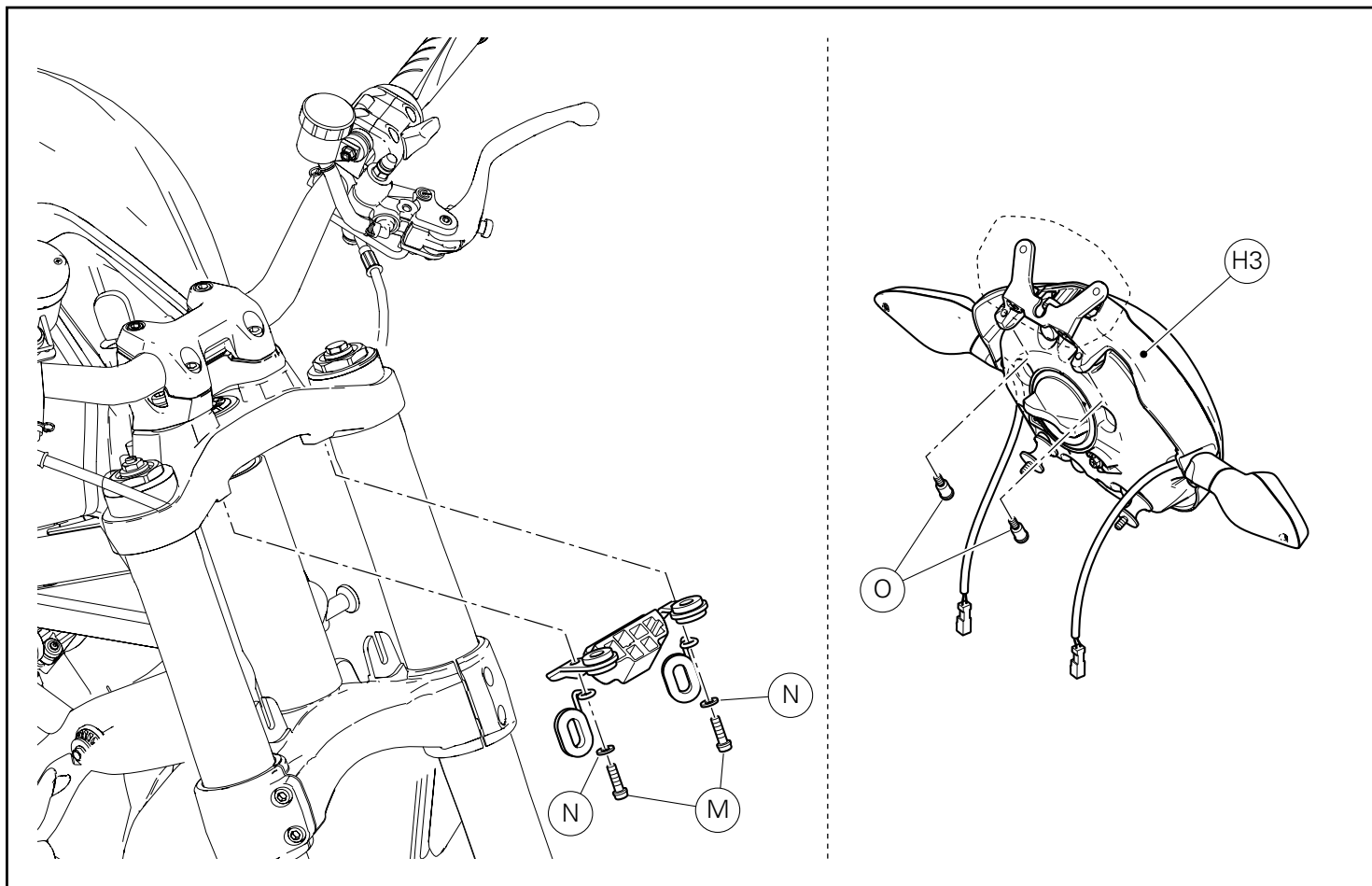

Desatarraxe os 2 parafusos (M) e as 2 anilhas (N).
Recupere as 2 anilhas (N).

Liberte os 2 pernos roscados (O) do suporte do farol (H3).

Loosen no. 2 screws (M) and no. 2 washers (N).
Keep no. 2 washers (N).

Release n.2 threaded pins (O) from headlight support (H3).

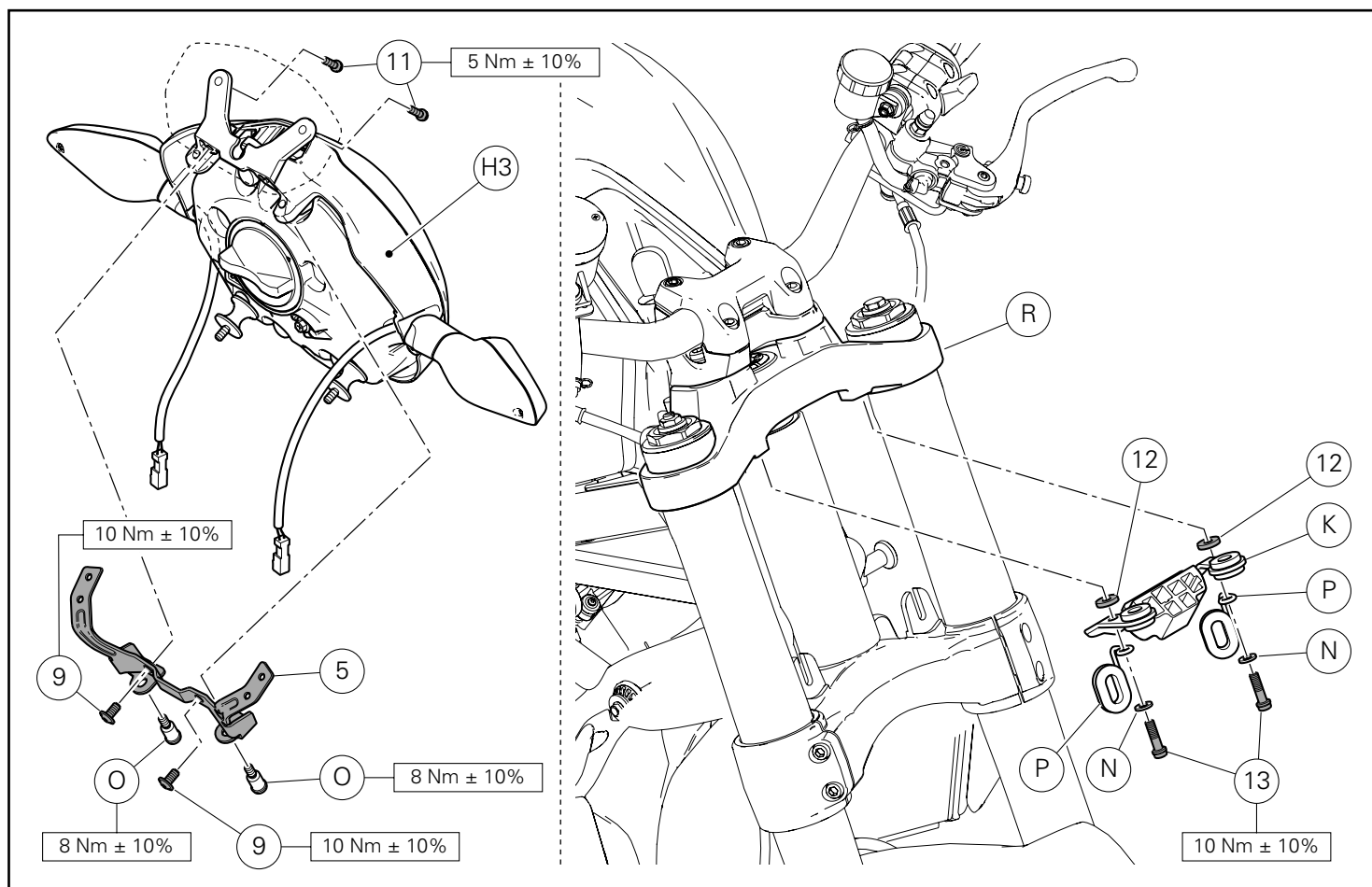

Montagem dos componentes

● Importante

Verifique, antes da montagem, se todos os componentes estão limpos e em perfeito estado.
Adote todas as precauções necessárias para evitar danificar qualquer peça com a qual deve trabalhar.

Encoste e aperte os 2 parafusos (11) ao binário indicado.
Posicione o grampo de suporte da cúpula (5) encoste os 2 parafusos (9) sem os apertar.
Atarraxe os 2 pernos roscados originais (O) no suporte do farol (H3), entrepondo o grampo (5).
Aperte os 2 pernos roscados (O) e os 2 parafusos (9) ao binário indicado.

Insira os 2 passa-tubos (P) e as 2 anilhas (N) nos 2 parafusos (13).

👁 Notas

Os passa-tubos (P) devem ser orientados para o lado externo da jarra da camisa das forquilhas.

Insira 2 anilhas (12) entre o grupo suporte dos conectores (K) e a cabeça de direção (R) em correspondência com os furos; atarraxe e aperte os 2 parafusos (13) ao binário indicado.

Kit installation

● Caution

Check that all components are clean and in perfect condition before installation.
Adopt any precaution necessary to avoid damages to any part of the motorcycle you are working on.

Start and tighten no. 2 screws (11) to the specified torque.
Position headlight fairing support bracket (5) and start no. 2 screws (9) without tightening them.
Screw no. 2 original threaded pins (O) onto the headlight support (H3) putting the bracket (5) in-between.
Tighten no. 2 threaded pins (O) and no. 2 screws (9) to the specified torque.

Insert the n.2 hose grommets (P) and the no.2 washers (N) into the no.2 screws (13).

👁 Notes

Hose grommets (P) shall be positioned towards the outer side of fork jacket leg.

Fit no. 2 washers (12) between connector support unit (K) and steering head (R) into the holes; screw and tighten no. 2 screws (13) to the specified torque.

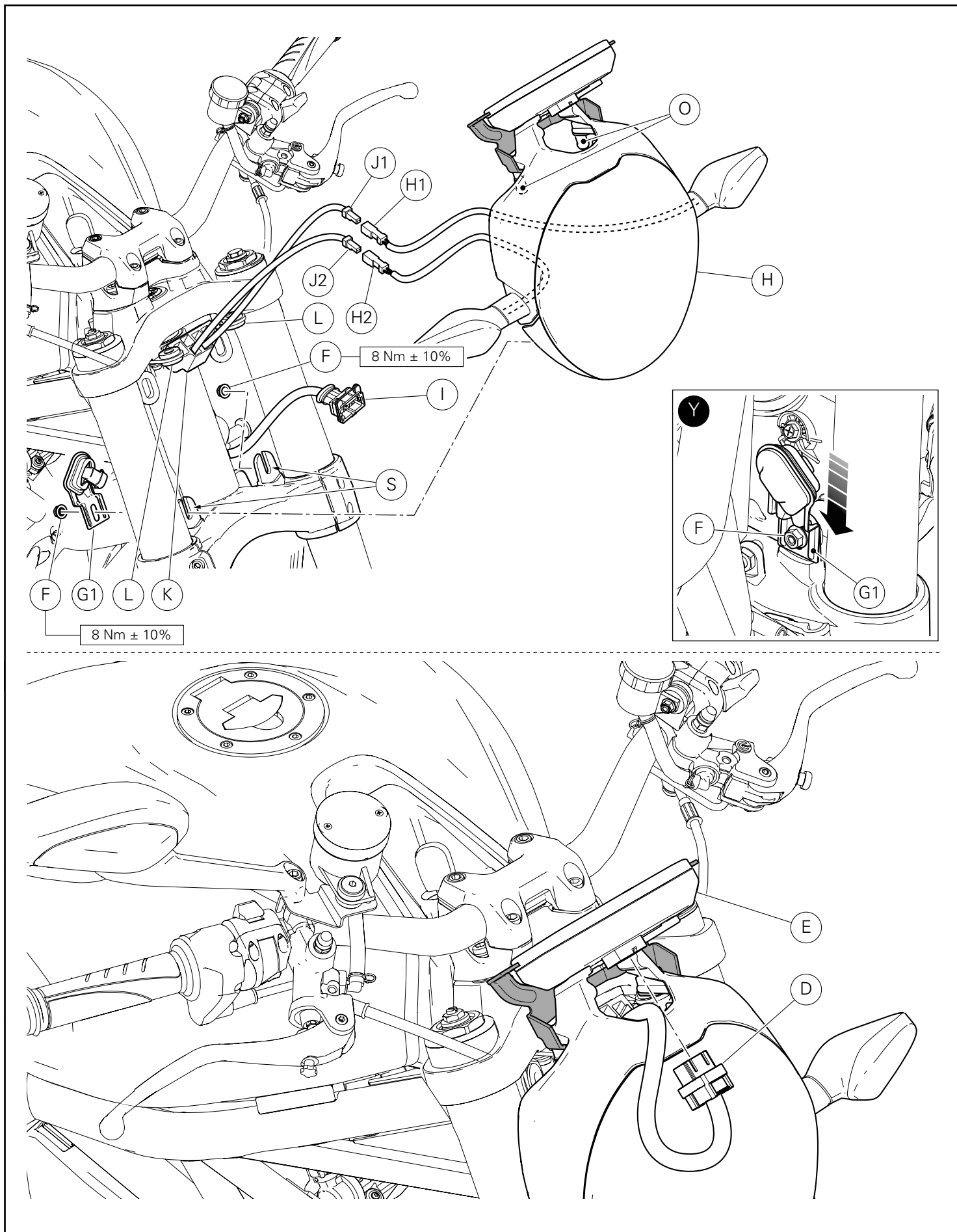

Ligue as tomadas (H1) e (H2) dos indicadores de direção pelas respectivas fichas (J1) e (J2) da cablagem principal.

Insira a ligação dos indicadores de direção no suporte dos conectores (K).

Posicione o grupo do farol dianteiro (H) com os pernos roscados (O) em correspondência dos anéis de borracha antivibrações (L) e empurre para baixo para encaixá-lo.

Ligue a ficha (I) na respetiva tomada existente no grupo do farol dianteiro (H).

Posicione os dois anéis anti-vibrações inferiores fixados no farol dianteiro com a rosca dentro das sedes (S) existentes na base de direção.

Insira o suporte do sensor de temperatura do ar (G1) na rosca do anel anti-vibrações direito e introduza as 2 porcas originais (F).



Notas

Durante o aperto da porca (F) mantenha o grampo de suporte do sensor (G1) premido para baixo (até bater na mesa de direção), para evitar que rodando entre em contacto com a jarra da forquilha, como indicado na figura (Y).

Fixe o farol dianteiro (H), atarraxando e apertando as 2 porcas (F) ao binário indicado

Ligue a conexão (D) no painel de instrumentos (E).

Verificação

Controle o efetivo funcionamento dos dispositivos óticos dianteiros:

- Indicador de direção esquerdo
- Indicador de direção direito
- Luz de presença
- Luz dos máximos e dos médios

No caso de mau funcionamento, verifique a correta fixação das tomadas com as fichas e a combinação justos das ramificações da cablagem.

Connect turn indicator plugs (H1) and (H2) to their sockets (J1) and (J2) in the main wiring.

Fit the turn indicators connectors to connector mounting plate (K). Secure the headlight assembly (H) with threaded pins (O) to the vibration dampers (L) and push downwards to engage it.

Disconnect the plug (I) from its socket on the headlight assembly (H).

Secure the two lower vibration dampers to the headlight so that the thread fits into the seats (S) placed on the bottom yoke.

Insert the air temperature sensor support (G1) on the thread of the right vibration damper and start the no.2 original nuts (F).



Notes

When tightening nut (F), hold sensor support bracket (G1) pressed down (against bottom yoke) to prevent its rotation which could make it interfere with the fork leg, as shown in figure (Y).

Secure headlight (H) by screwing and tightening no. 2 nuts (F) to the specified torque.

Connect wiring connectors (D) to instrument panel (E).

Inspection

Ascertain that the front lights are functioning properly:

- Left turn indicator
- Right turn indicator
- Parking light
- Low and high beam

In case of malfunction, check the plugs and sockets are properly connected and that wiring connectors have been matched correctly.

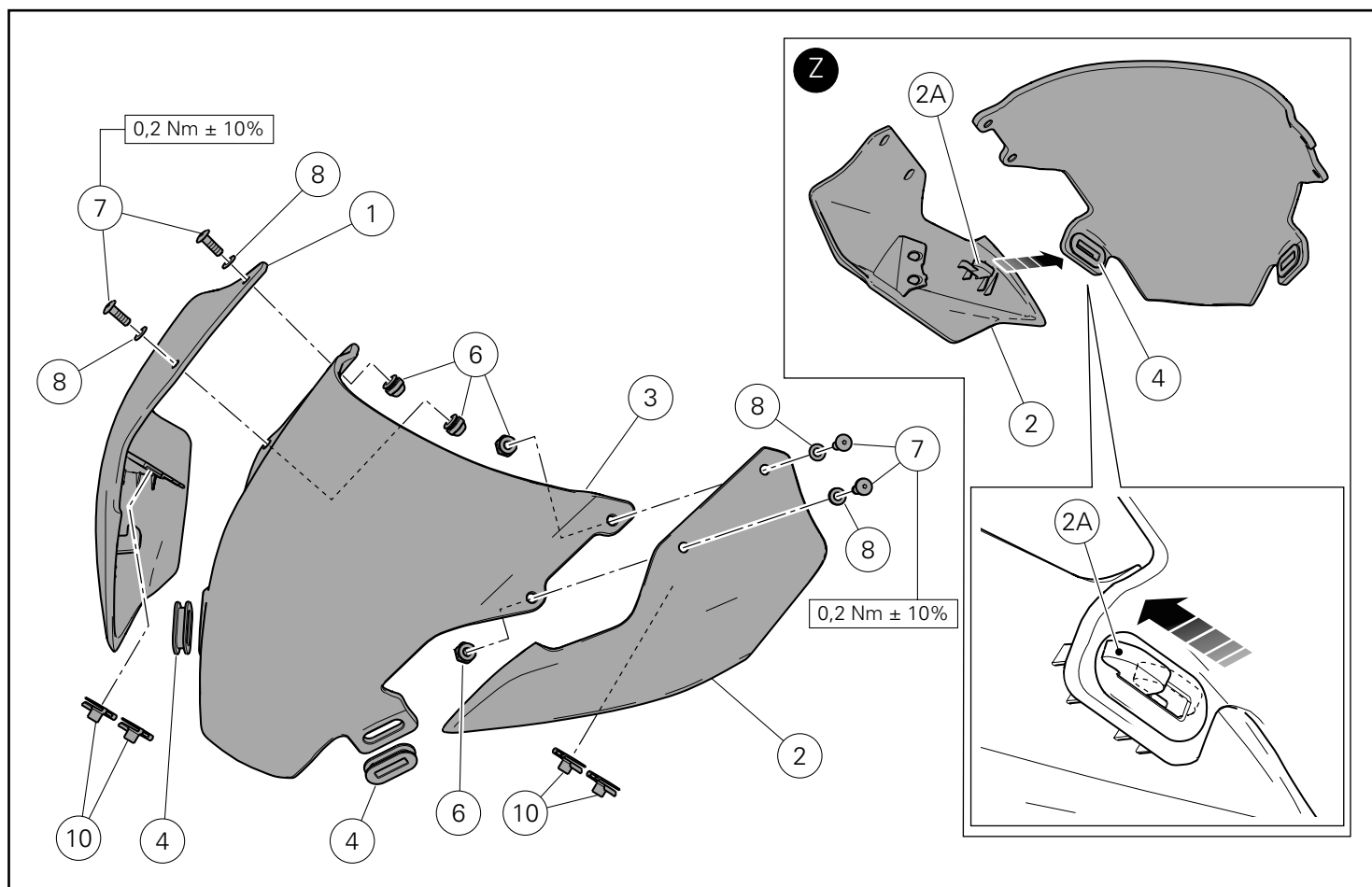

Pré-montagem do grupo cúpula

Pré-monte os 4 clips (10) na face da cúpula direita (1) e esquerda (2).

Pré-monte os 2 anéis de borracha (4) no para-brisas (3).

Insira o dente (2A) presente na face da cúpula esquerda (2) no anel de borracha (4) acabado de montar e puxe para trás para encaixar a face esquerda (2) no para-brisas (3), como mostrado na figura (Z).

Insira as 2 anilhas de nylon (8) nos 2 parafusos (7).

Encoste, do lado externo, os 2 parafusos (7) e atarraxe, do lado interno, as 2 porcas elásticas (6).

Aperte os 2 parafusos (7) ao binário indicado.

Repita a mesma operação para a montagem da face da cúpula direita (1) no para-brisas (3).

Headlight fairing unit pre-assembly

Pre-assemble no. 4 clips (10) on RH (1) and LH (2) headlight fairing panels.

Pre-assemble no. 2 rubber elements (4) on windscreen (3).

Fit retainer (2A) on LH headlight fairing panel (2) into rubber element (4) just assembled and pull backwards to engage LH panel (2) to windscreen (3), as shown in figure (Z).

Fit no. 2 nylon washers (8) on no. 2 screws (7).

Start no. 2 screws (7), from the outer part, and screw no. 2 spring nuts (6) from the inner part.

Tighten no. 2 screws (7) to the specified torque.

Repeat the same procedure to assemble RH headlight fairing panel (1) on windscreen (3).

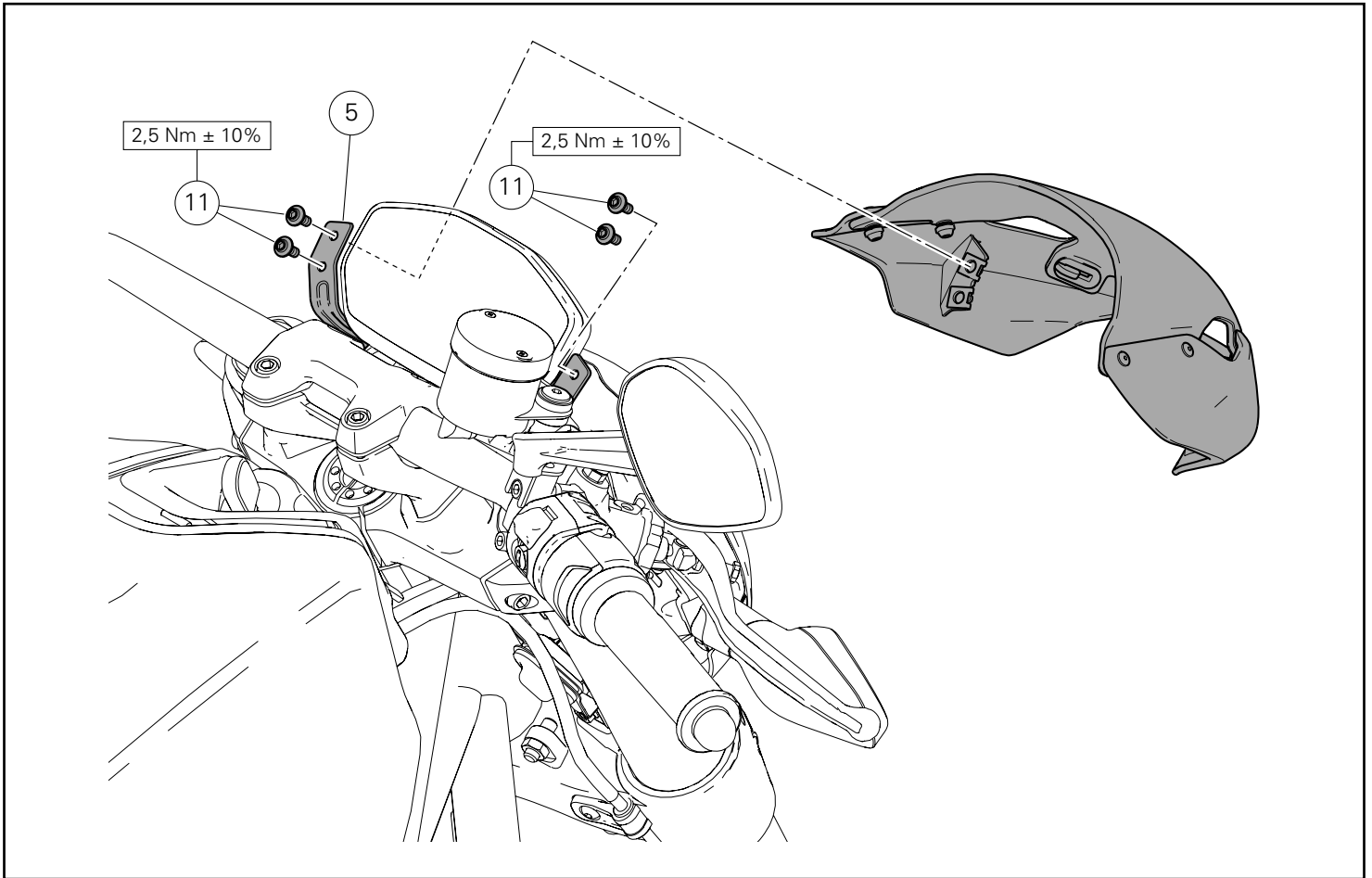

Posicione o grupo cúpula acabado de pré-montar na braçadeira (5) e encoste 4 parafusos (11).
Aperte os 4 parafusos (11) ao binário indicado.

Position headlight fairing unit just pre-assembled on bracket (5) and start no. 4 screws (11).
Tighten no. 4 screws (11) to the specified torque.

Kit cúpula ヘッドライトフェアリングキット



Símbolos

Para una lectura rápida y racional se han empleado símbolos que evidencian situaciones de máxima atención, consejos prácticos o simples informaciones. Prestar mucha atención al significado de los símbolos porque su función consiste en omitir la repetición de conceptos técnicos o advertencias de seguridad. Los símbolos deben considerarse como verdaderos "apuntes". Consultar esta página cada vez que se tengan dudas sobre su significado.



Atención

El incumplimiento de las instrucciones indicadas puede crear una situación de peligro y ocasionar graves lesiones e incluso la muerte.



Importante

Indica la posibilidad de provocar un daño al vehículo y/o a sus componentes si no se siguen las instrucciones indicadas.



Notas

Suministra útiles informaciones sobre la operación en curso.

Referencias

Las partes resaltadas en gris y la referencia numérica (Por ej. ①) representan el accesorio que se debe instalar y los eventuales componentes de montaje suministrados en el kit.

Las partes con referencia alfabética (Por ej. Ⓐ) representan los componentes originales presentes en la motocicleta.

Todas las indicaciones derecha o izquierda se refieren al sentido de marcha de la motocicleta.

Advertencias generales



Atención

Las operaciones descritas en las siguientes páginas deben realizarse correctamente para no perjudicar la seguridad del piloto.



Atención

Las operaciones descritas en las siguientes páginas deben realizarse correctamente para no perjudicar la seguridad del piloto.



Notas

La documentación necesaria para realizar el montaje del Kit es el: MANUAL DE TALLER, relativo al modelo de moto en vuestro poder.



Notas

Si fuera necesario sustituir un componente del kit, consultar la tabla de recambios adjunta.

シンボル

素早くかつ合理的に読み進めることができるように、本マニュアルではいくつかのシンボルを導入し、最大限の注意を払う必要がある状況や、推奨事項、または一般情報を明確にしています。技術的概念や安全に関する警告を繰り返し記載する必要がないように機能しているので、各シンボルの意味に十分注意してください。シンボルは、実際上の“覚え書き”であると考えてください。シンボルなどの意味がわからなくなったり疑問に思う場合は、必ずこのページで調べるようにしてください。



注記

この説明書に従わずに使用すると危険な状況を招き、重大なけが、あるいは死をももたらす原因となることがあります。



重要

この説明書に従わずに使用すると、車体及び/ 又はその部品に損害を招く可能性があります



参考

操作中の内容に関する有用な情報を掲載しています。

参照

灰色で表示する部品、および参照番号 (Es. ①) で表示する部品は、キットに付属する取り付け部品および組み立て部品を示します。

参照アルファベット (Es. Ⓐ) で表示する部品は、車両に付属するオリジナル部品を示します。

すべての右及び左の指示は車体の進行方向を向いたものです。

一般警告事項



警告

以下のページに記載されている作業が規定通りに実施されない場合、ライダーの安全性を脅かすおそれがあります。



警告

以下のページに記載されている作業が規定通りに実施されない場合、ライダーの安全性を脅かすおそれがあります。



参考

キットの取り付けに必要な資料：お手持ちの車両モデルに対応するワークショップマニュアル。



参考

キットの部品を交換する必要がある場合は、添付のスペアパーツ表を参照してください。

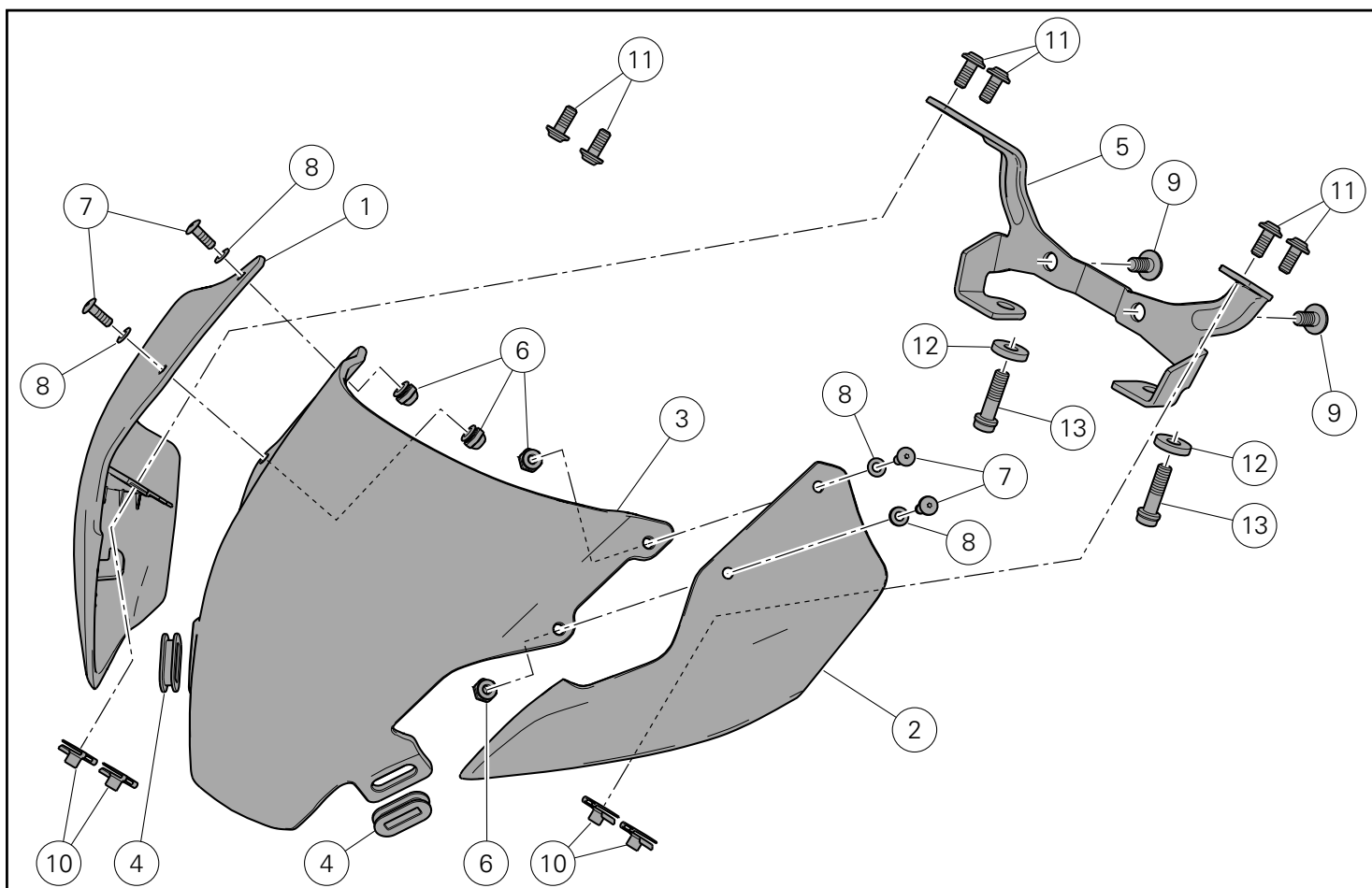

Pos.	Denominacion	説明
1	Panel cúpula derecha	右ヘッドライトフェアリングカバー
2	Panel cúpula izquierda	左ヘッドライトフェアリングカバー
3	Parabrisas central	センターウィンドスクリーン
4	Junta	ラバー
5	Sostén soporte cúpula	ヘッドライトフェアリングマウントブラケット
6	Tuerca elástica	スプリングナット
7	Tornillo especial TB M4x12	専用スクリュー TB M4x12
8	Arandela de nylon	ナイロンワッシャー
9	Tornillo especial TBEIF M6x12	TBEIF M6x12スクリュー
10	Clip	クリップ
11	Tornillo especial TBEI M5x12	スクリュー TBEI M5x12
12	Arandela	ワッシャー
13	Tornillo TCEIF M6x22	スクリュー TCEIF M6x22

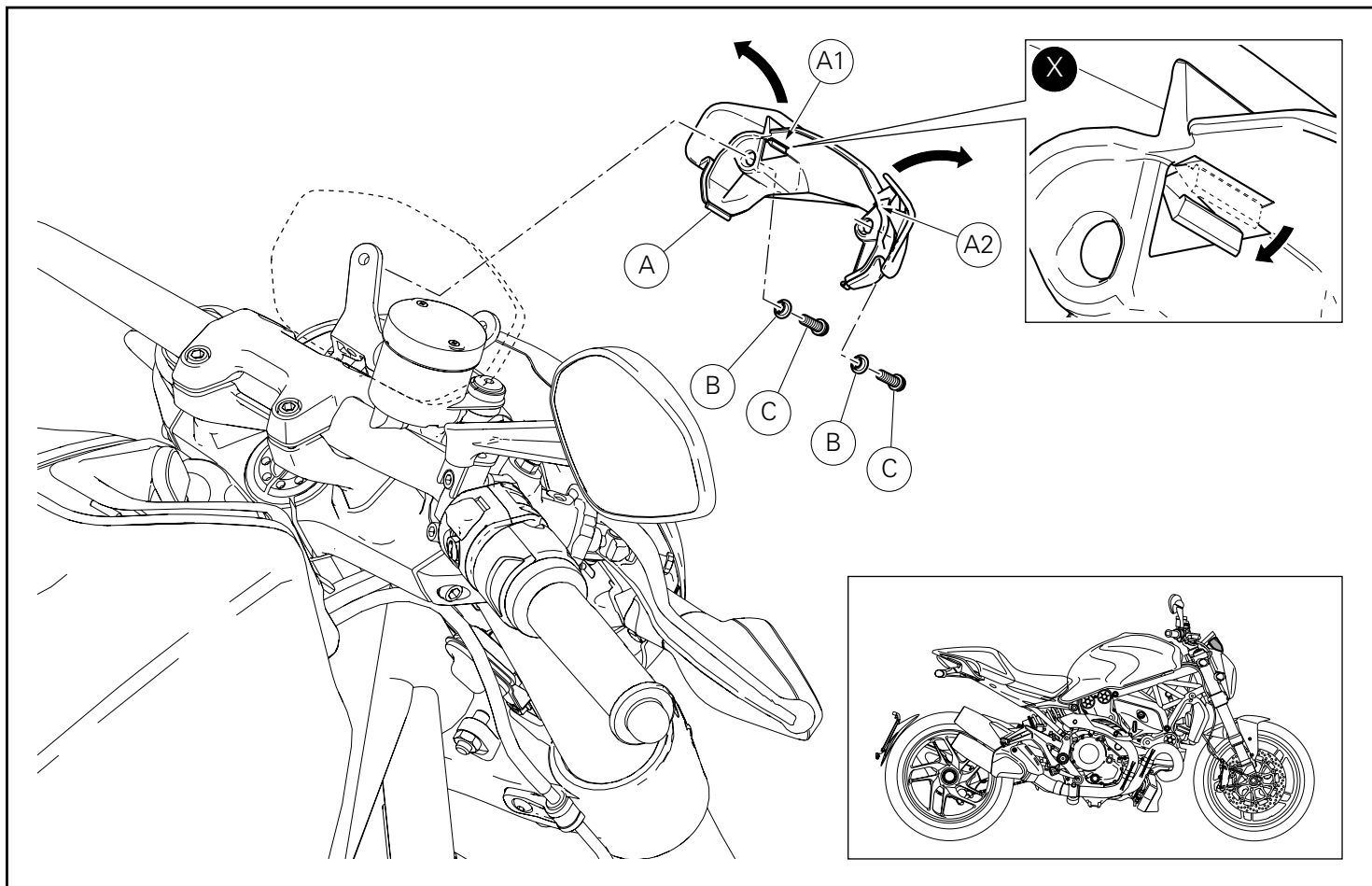

Desmontaje componentes originales

Notas

El procedimiento de montaje del kit es el mismo para todas las motocicletas Monster 1200 y Monster 821 donde es utilizado, como ejemplo, el procedimiento que se debe adoptar en el modelo Monster 1200.

Abrir las dos aletas del cover salpicadero (A) desenganchando los dos dientes (A1) y (A2), como indica la figura (X).

Desatornillar los 2 tornillos (C) y quitar los 2 separadores (B) y el cover salpicadero (A).

オリジナル部品の取り外し

注意

キットの取り付け手順はすべての Monster 1200 および Monster 821 モーターサイクルに共通です。ここでは例として Monster 1200 モデルの作業手順を記載しています。

図 (X) のように、2 つのつめ (A1) および (A2) を外し、インストルメントパネルカバー (A) の 2 つのタブを開きます。2 本のスクリュー (C) を緩め、2 個のスペーサー (B) およびインストルメントパネルカバー (A) を取り外します。

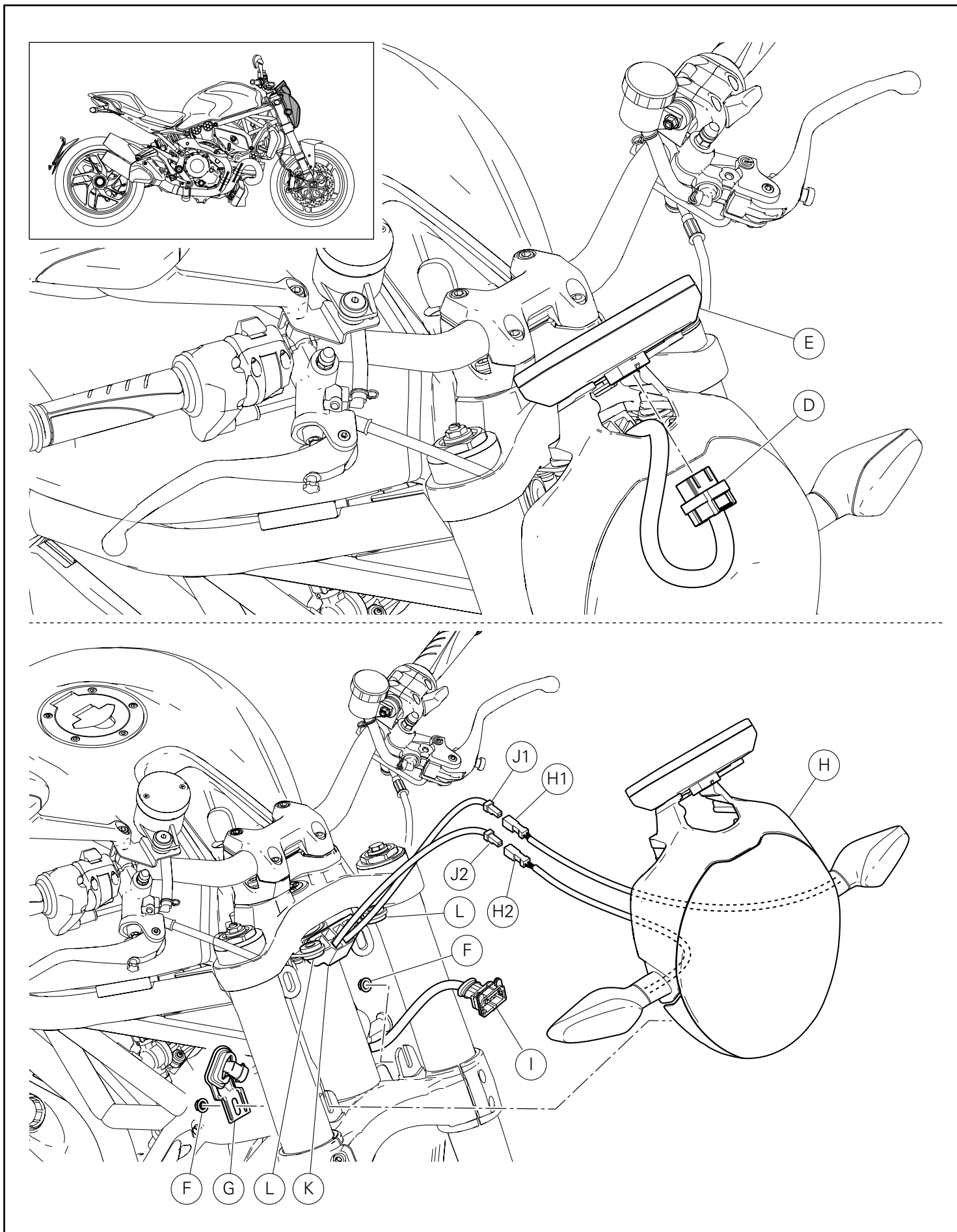

Desconectar la conexión (D) del salpicadero (E).

Desatornillar las 2 tuercas (F).



Importante

Durante la fase de desmontaje de la tuerca derecha, prestar mucha atención de no dañar el sensor temperatura aire (G) soportándolo de manera adecuada.

Desconectar la clavija (I) de su respectiva toma presente en el grupo faro delantero (H).

Quitar el grupo faro delantero (H) desenganchándolo de las gomas antivibrantes (L).

Extraer la conexión de los indicadores de dirección del soporte conectores (K).

Desconectar las tomas (H1) y (H2) de los indicadores de dirección de sus respectivas clavijas (J1) y (J2) del cableado principal.

インストルメントパネル (E) から接続部品 (D) を切り離します。

2 個のナット (F) を緩めます。



重要

右ナットを取り外す際、外気温センサー (G) を適切に支え破損しないよう注意してください。

プラグ (I) をヘッドライトユニット (H) 上の対応するソケットから切り離します。

ヘッドライトユニット (H) を耐震ラバー (L) から外し、取り外します。

ターンインジケータの接続部品をコネクターマウント (K) から抜き取ります。

ターンインジケータのソケット (H1) および (H2) を主要配線の対応するプラグ (J1) および (J2) から切り離します。

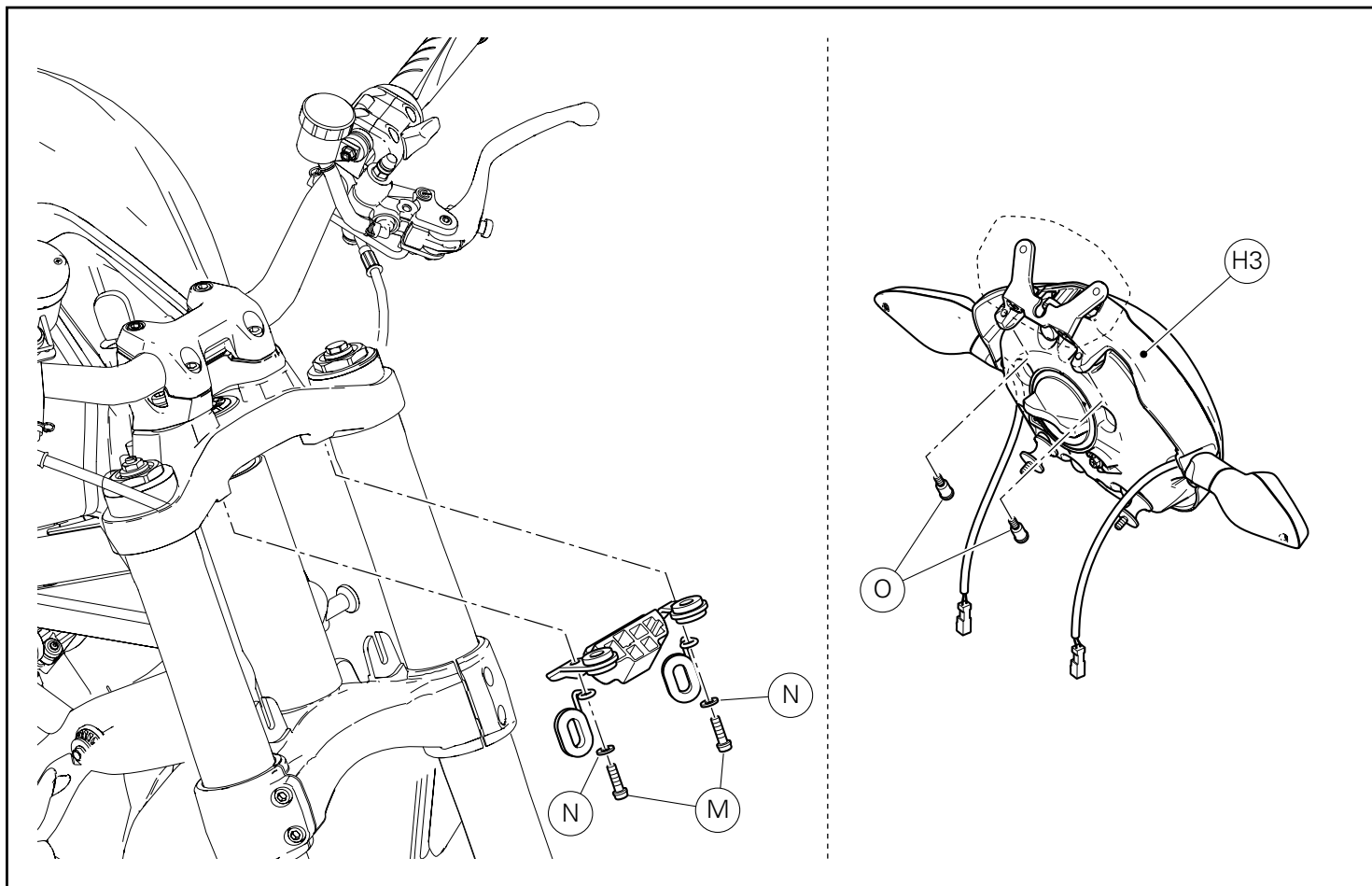

Desatornillar los 2 tornillos (M) y las 2 arandelas (N).
Recuperar las 2 arandelas (N).

Liberar los 2 pernos roscados (O) del soporte faro (H3).

2 本のスクリュー (M) および 2 個のワッシャー (N) を緩めて外
します。

2 個のワッシャー (N) を回収します。

2 個のスレッド付きピン (O) をヘッドライトマウント (H3) から
外します。

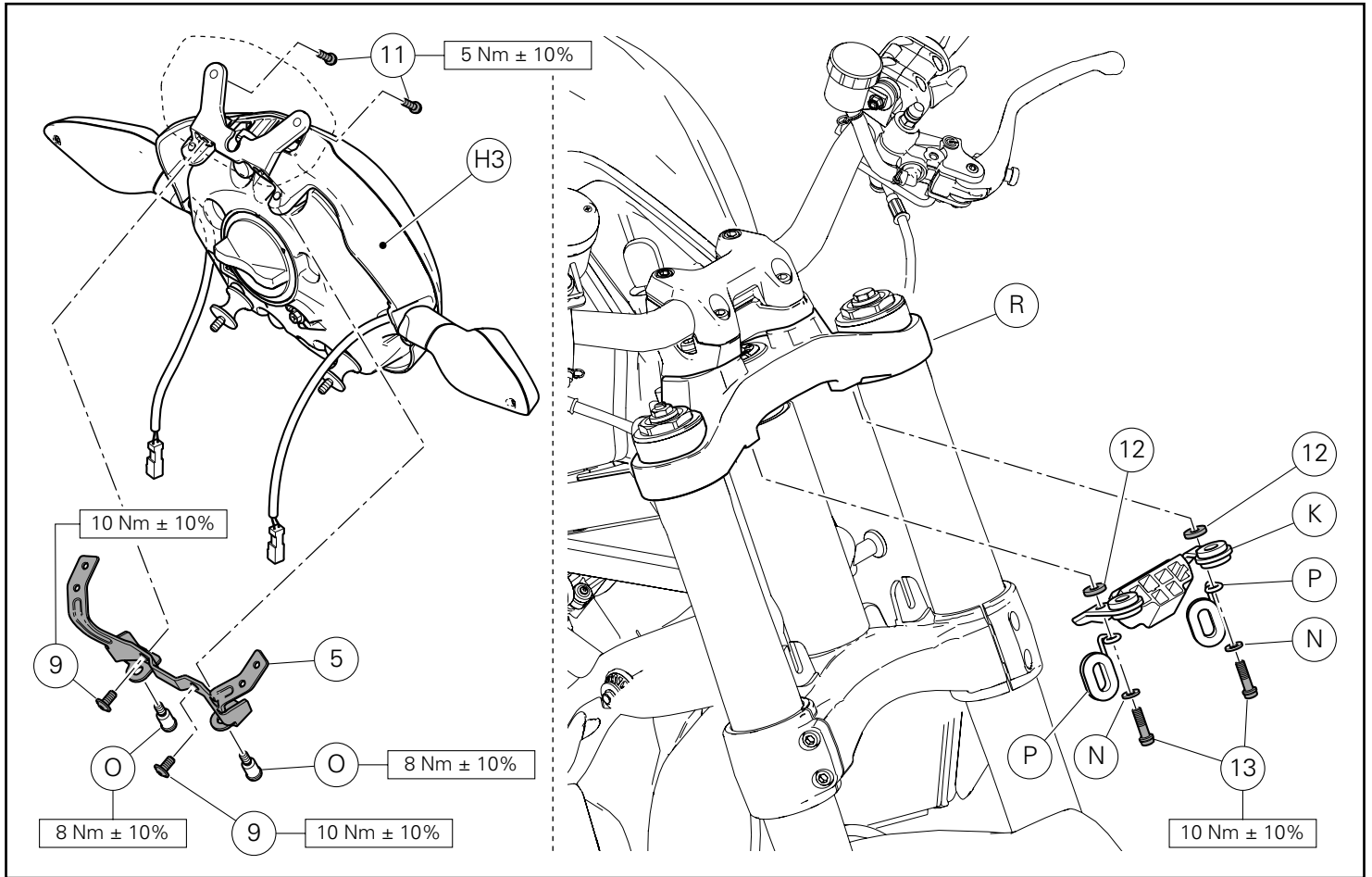

Montaje componentes kit

● Importante

Controlar, antes del montaje, que todos los componentes se encuentren limpios y en perfecto estado. Adoptar todas las precauciones necesarias para evitar daños en la superficie exterior de los componentes donde se debe operar.

Introducir y ajustar los 2 tornillos (11) al par de apriete indicado. Posicionar el sostén soporte cúpula (5) e introducir los 2 tornillos (9) sin ajustarlos.

Atornillar los 2 pernos roscados originales (O) en el soporte faro (H3) interponiendo el sostén (5).

Ajustar los 2 pernos roscados (O) y los 2 tornillos (9) al par de apriete indicado.

Introducir los 2 pasatubos (P) y las 2 arandelas (N) en los 2 tornillos (13).

👁 Notas

Los pasatubos (P) se deben orientar hacia el lado exterior de la barra camisa horquillas.

Introducir 2 arandelas (12) entre el grupo soporte conectores (K) y la tija superior (R) en correspondencia de los orificios; atornillar y ajustar los 2 tornillos (13) al par de apriete indicado.

キット部品の取り付け

● 重要

取り付け前にすべての部品に汚れがなく、完璧な状態であることを確認します。作業する部品の外側表面を傷つけないために、必要な予防措置を取ってください。

2本のスクリュー（11）を差し込み、規定のトルクで締め付けます。

ヘッドライトフェアリングマウントブラケット（5）を配置し、2本のスクリュー（9）を締め付けずに差し込みます。

2本のスレッド付きオリジナルピン（O）をヘッドライトマウント（H3）にねじ込みます。この時、ブラケット（5）を間に挟みます。

2本のスレッド付きピン（O）および2本のスクリュー（9）を規定のトルクで締め付けます。

2本のホースガイド（P）および2個のワッシャー（N）を2本のスクリュー（13）に挿入します。

👁 注意

ホースガイド（P）はアウターチューブの外側に向けます。

2個のワッシャー（12）をコネクタマウントユニット（K）およびステアリングヘッド（R）の間の穴の位置に挿入します。

2本のスクリュー（13）をねじ込み、規定のトルクで締め付けます。

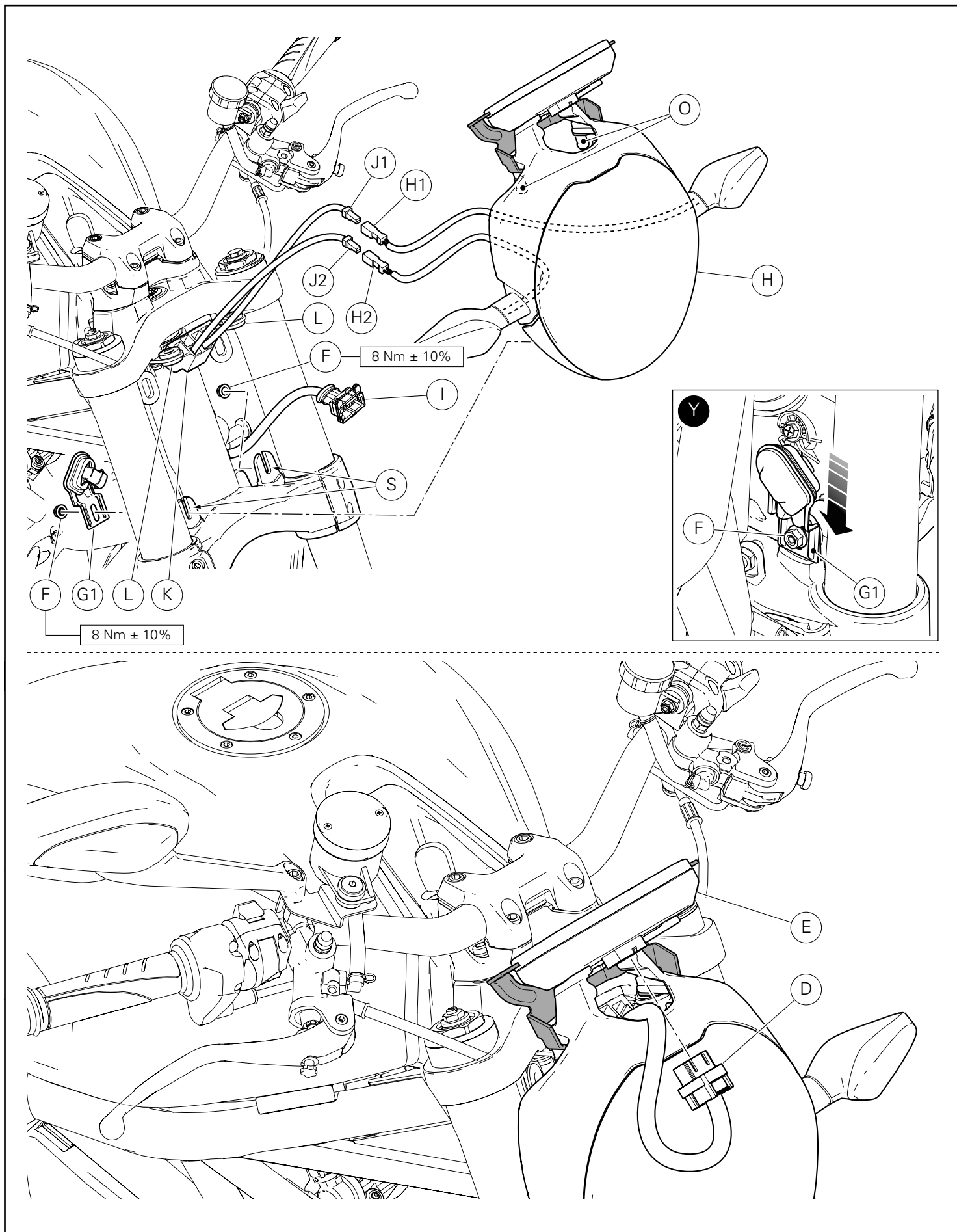

Conectar las tomas (H1) y (H2) de los indicadores de dirección a sus respectivas clavijas (J1) y (J2) del cableado principal. Introducir la conexión de los indicadores de dirección en el soporte conectores (K).

Posicionar el grupo faro delantero (H) con los pernos roscados (O) en correspondencia de las gomas antivibrantes (L) y empujar hacia abajo para encastrarlo.

Conectar la clavija (I) en su respectiva toma presente en el grupo faro delantero (H).

Posicionar los dos antivibrantes inferiores fijados al faro delantero con la rosca en el interior de los alojamientos (S) presentes en la tija de dirección.

Introducir el soporte sensor temperatura aire (G1) en la rosca del antivibrante derecho e introducir las 2 tuercas originales (F).

Montaje colectores centrales

Asegurarse de que la abrazadera original (E) se encuentre en posición sobre el colector vertical fijado a la culata.

Introducir el colector central vertical original (F) en el colector vertical fijado a la culata a tope.

Llevar a posición en el colector central vertical (F) la abrazadera (E) y ajustarla al par de apriete indicado.



Notas

Durante el ajuste de la tuerca (F) mantener el sostén soporte sensor (G1) presionado hacia abajo (a tope en la tija de dirección) para evitar que al girar tome contacto con la barra de la horquilla, como indica la figura (Y).

Fijar el faro delantero (H) atornillando y ajustando las 2 tuercas (F) al par de apriete indicado.

Conectar la conexión (D) al salpicadero (E).

Control

Controlar el correcto funcionamiento de los dispositivos ópticos delanteros:

- Indicador de dirección izquierdo
- Indicador de dirección derecho
- Luz trasera
- Luz de carretera y de cruce

En caso de funcionamiento incorrecto, controlar la correcta fijación de las tomas y clavijas y la adecuada combinación de los tramos de cableado.

Turn indicator sockets (H1) and (H2) to the main wiring corresponding plug (J1) and (J2).

Turn indicator connector parts to the turner mount (K) and insert them.

Headlight unit (H) with the screw pins (O) together with the vibration rubber (L) in the position and push it firmly into place.

Plug (I) into the corresponding socket on the headlight unit (H).

Headlight unit (H) is fixed with 2 screws to the lower vibration rubber on the bottom yoke (S) and insert it into the interior. Insert the outside temperature sensor mount (G1) into the screw part of the right vibration rubber and insert the 2 original nuts (F).



注意

When tightening the nut (F), avoid contact with the fork leg by turning it. To avoid this, turn (Y) the sensor mount bracket (G1) downwards as shown (until it hits the bottom yoke).

Turn the 2 nuts (F) by hand to the specified torque and fix the headlight (H).

Connect the connector parts (D) to the instrument panel (E).

点検

Check that the function of the front optical device is appropriate.

- Left turn indicator connector
- Right turn indicator connector
- Parking lamp
- High beam lamp and low beam lamp

If there are any problems, check that the plug is correctly fixed to the socket and that the wiring is correctly connected.

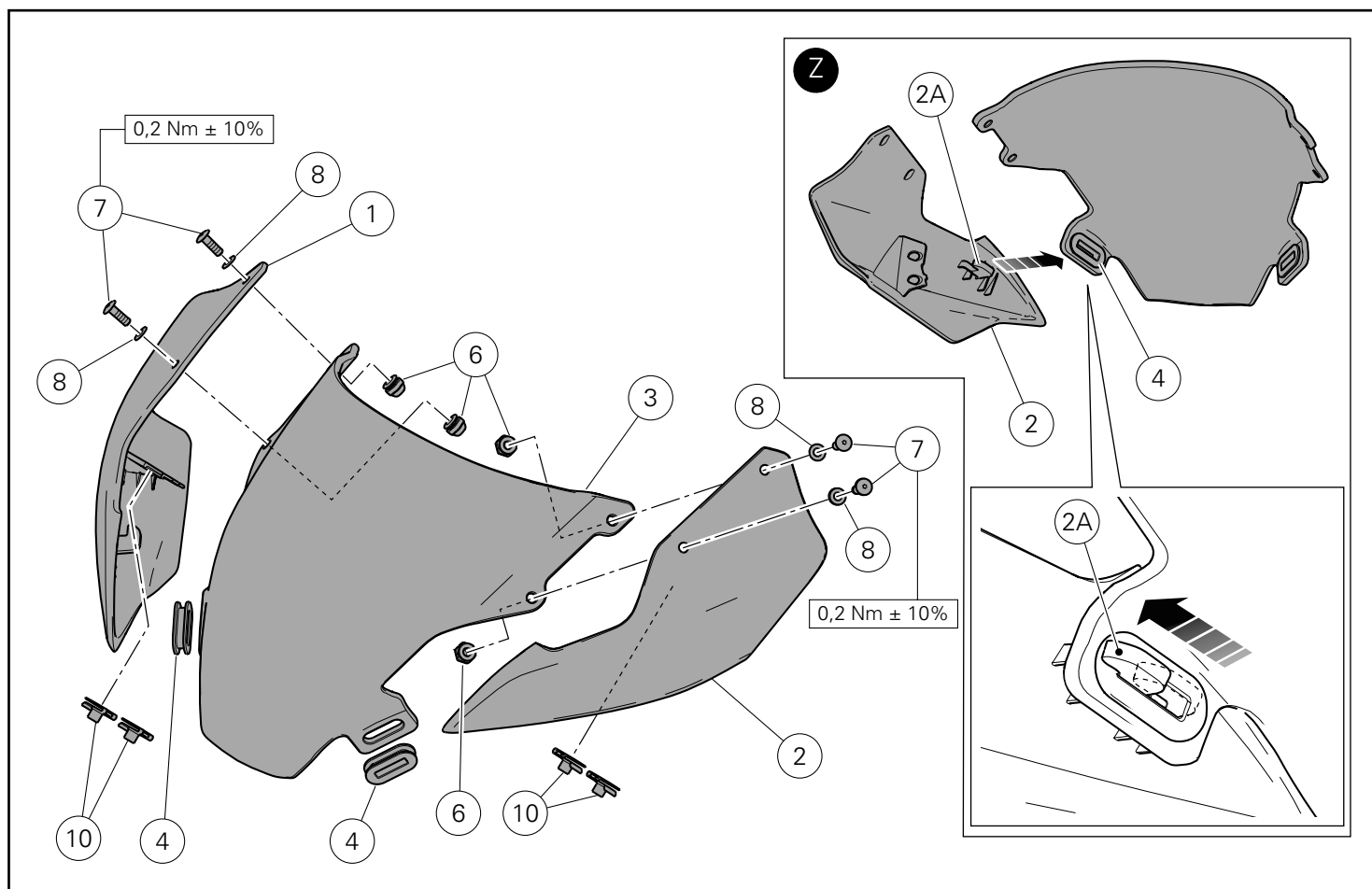

Pre-montaje grupo cúpula

Pre-montar los 4 clips (10) en el panel cúpula derecho (1) e izquierdo (2).

Pre-montar las 2 gomas (4) en el parabrisas (3).

Introducir el diente (2A) presente en el panel cúpula izquierdo (2) en la goma (4) apenas montada y tirar hacia atrás para encastrar el panel izquierdo (2) al parabrisas (3), como ilustra la figura (Z).

Introducir las 2 arandelas de nylon (8) en los 2 tornillos (7).

Introducir la parte exterior, los 2 tornillos (7) y atornillar, desde la parte interior, las 2 tuercas elásticas (6).

Ajustar los 2 tornillos (7) al par de apriete indicado.

Repetir esta misma operación para montar el panel cúpula derecho (1) en el parabrisas (3).

ヘッドライトフェアリングユニットの仮取り付け

4本のクリップ(10)を右ヘッドライトフェアリングカバー(1)および左ヘッドライトフェアリングカバー(2)に仮取り付けします。

2個のラバー(4)をウィンドスクリーン(3)に仮取り付けします。

図(Z)のように、左ヘッドライトフェアリングカバー(2)のつめ(2A)を先ほど取り付けしたラバー(4)に挿入し、左カバー(2)をウィンドスクリーン(3)に向けて後ろに引っ張り、噛み合わせます。

2個のナイロンワッシャー(8)を2本のスクリュー(7)に挿入します。

2本のスクリュー(7)を外側から差し込み、2個のスプリングナット(6)を内側からねじ込みます。

2本のスクリュー(7)を規定のトルクで締め付けます。

同様に作業し、右ヘッドライトフェアリングカバー(1)をウィンドスクリーン(3)に取り付けます。

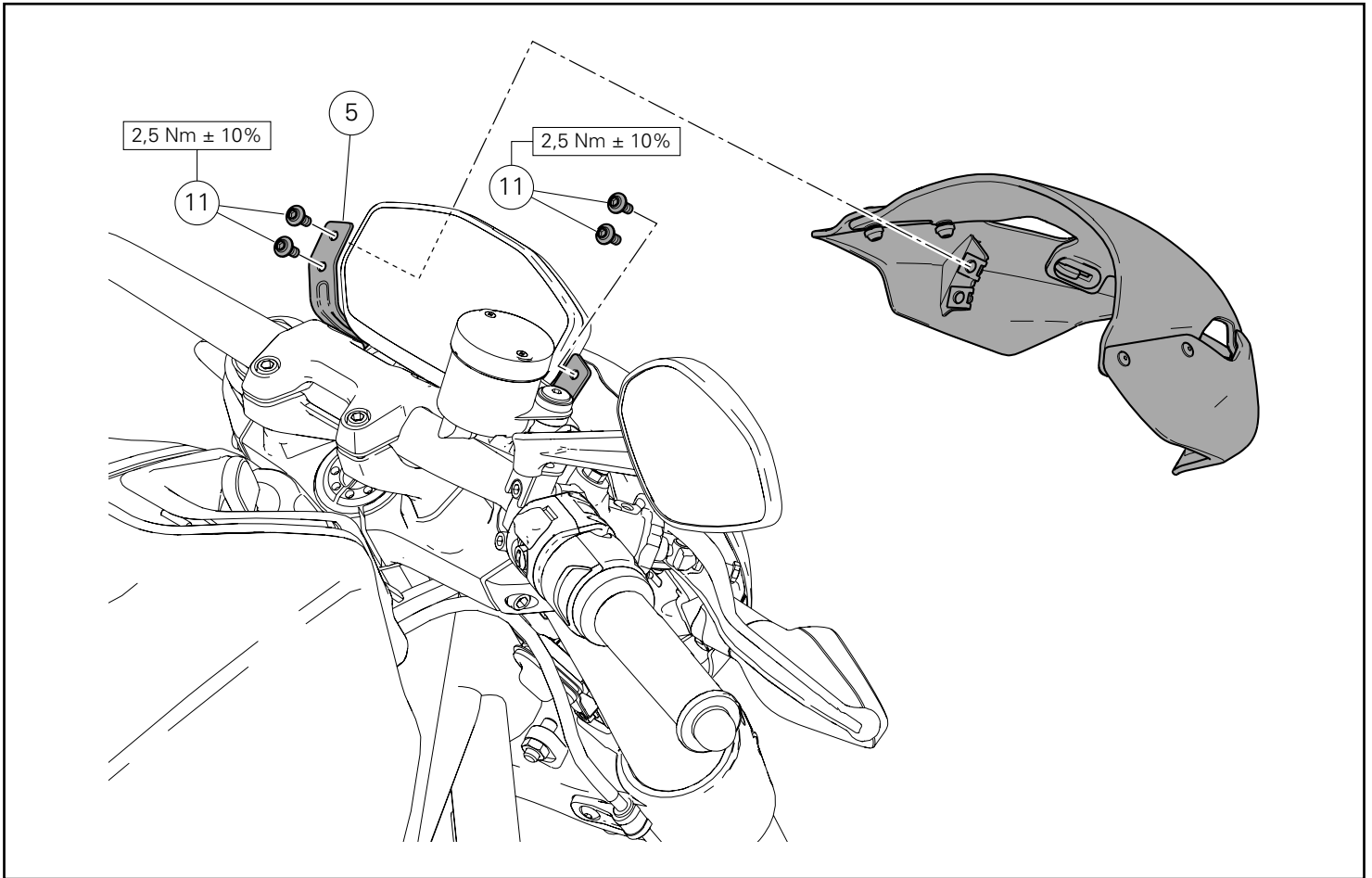

Posicionar el grupo cúpula apenas pre-montado en el sostén (5) e introducir los 4 tornillos (11).
Ajustar los 4 tornillos (11) al par de apriete indicado.

先ほど仮取り付けしたヘッドライトフェアリングユニットをブラケット (5) に配置し、4 本のスクリュー (11) を差し込みます。4 本のスクリュー (11) を 規定のトルクで締め付けます。



DUCATI PERFORMANCE accessories

レース専用部品 ご注文書

ご注文商品

1 P/N

商品名

2 P/N

商品名

3 P/N

商品名

4 P/N

商品名

5 P/N

商品名

お客様ご記入欄

私は上記レース専用部品を下記車両に装着し、サーキット走行のみに利用し、一般公道には利用しません。

車台番号 ZDM

モデル名

お客様署名

ご注文日

ドゥカティ正規ネットワーク店記入欄

お客様に上記レース専用部品を販売し、レース専用部品のご利用方法を説明いたしました。

販売店署名

販売日

年

月

日

販売店様へお願い

- 上記ご記入の上、弊社アフターセールス部までFAXしてください。FAX:03-6692-1317
- 取り付け車両1台に1枚でご使用ください。



Kit cupolino / Headlight fairing kit / Kit bulle / Kit Cockpitverkleidung / Conjunto cúpula / Kit cúpula / ヘッドライトフェアアリングキット

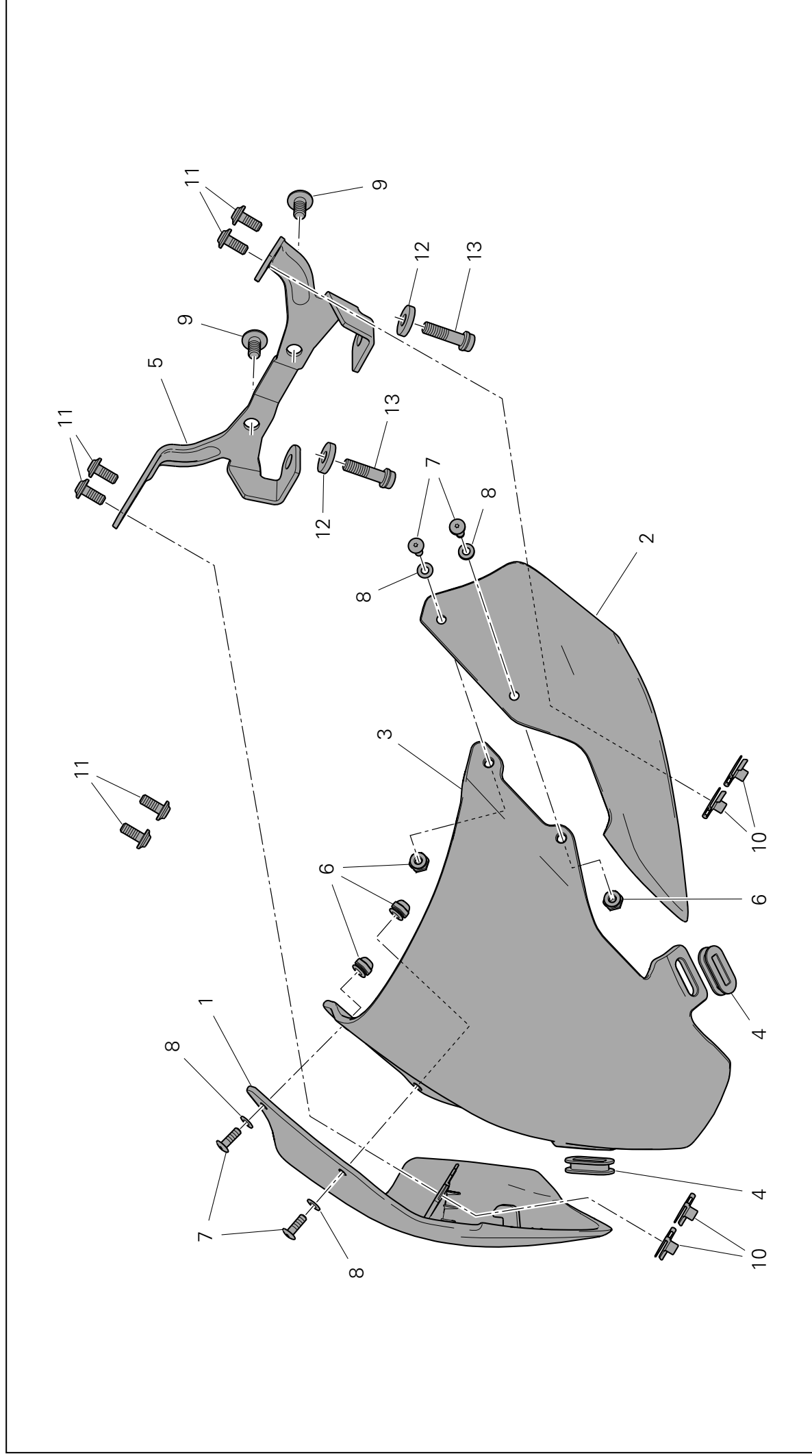

Pos.	Cod.	Denominazione	Description	Designation	Bezeichnung	Descrição	Denominacion	説明	O.ty
1	48111241AA	Guancia cupolino destra	RH headlight fairing panel	Joue bulle droite	Rechte Cockpitverkleidungsschale	Face droite da cúpula	Panel cúpula derecha	右ヘッドライトフェアリングカバー	1
2	48111251AA	Guancia cupolino sinistra	LH headlight fairing panel	Joue bulle gauche	Linke Cockpitverkleidungsschale	Face esquerda da cúpula	Panel cúpula izquierda	左ヘッドライトフェアリングカバー	1
3	48710871A	Parabrezza centrale	Central windscreen	Pare-brise central	Mittlerer Fahrtwindschutz	Para-brisas central	Parabrisas central	センターウインドスクリーン	1
4	76412221A	Gommino	Rubber block	Plot caoutchouc	Gummielement	Anel de borracha	Junta	ラバー	2
5	8291E581AA	Staffa supporto cupolino	Headlight fairing support bracket	Bride de support bulle	Stützbügel für Cockpitverkleidung	Grampo de suporte da cúpula	Sostén soporte cúpula	ヘッドライトフェアリングマウントブラケット	1
6	75010281A	Dado elastico	Spring nut	Écrou élastique	Elastische Mutter	Porca elástica	Tuerca elástica	スプリングナット	4
7	77510071AB	Vite speciale TB M4x12	TB special screw M4x12	Vis spéciale TB M4x12	Spezialschraube TB M4x12	Parafuso especial de cabeça abaulada M4x12	Tornillo especial TB M4x12	専用スクリーン TB M4x12	4
8	85210241A	Rosetta in nylon	Nylon washer	Rondelle en nylon	Unterlegscheibe aus Nylon	Anilha de nylon	Arandela de nylon	ナイロンワッシャー	4
9	77240403C	Vite TBEIF M6x12	TBEIF screw M6x12	Vis TBHCF M6x12	Linsennensechskantschraube M6x12	Parafuso de cabeça abaulada flangeada com sextavado interno M6x12	Tornillo especial TBEIF M6x12	TBEIF M6x12 スクリュー	2
10	85040471A	Clip	Clip	Clip	Clip	Clip	Clip	クリップ	4
11	77244173B	Vite TBEI M5x12	TBEI screw M5x12	Vis TBHC M5x12	Linsennensechskantschraube M5x12	Parafuso de cabeça abaulada com sextavado interno M5x12	Tornillo especial TBEI M5x12	スクリーン TBEI M5x12	6
12	85212751A	Rosetta	Washer	Rondelle	Unterlegscheibe	Anilha	Arandela	ワッシャー	2
13	77110461A	Vite TCEIF M6x22	TCEIF screw M6x22	Vis TCHCF M6x22	Geflanschte Innensechskantschraube M6x22	Parafuso de cabeça cilíndrica flangeada com sextavado interno M6x22	Tornillo TCEIF M6x22	スクリーン TCEIF M6x22	2