

Kit borsa serbatoio magnetica stagna OUTDOOR Sealed magnetic tank bag kit - OUTDOOR



Simbologia

Per una lettura rapida e razionale sono stati impiegati simboli che evidenziano situazioni di massima attenzione, consigli pratici o semplici informazioni.

Prestare molta attenzione al significato dei simboli, in quanto la loro funzione è quella di non dovere ripetere concetti tecnici o avvertenze di sicurezza. Sono da considerare, quindi, dei veri e propri "promemoria".

Consultare questa pagina ogni volta che sorgeranno dubbi sul loro significato.



Attenzione

La non osservanza delle istruzioni riportate può creare una situazione di pericolo e causare gravi lesioni personali e anche la morte.



Importante

Indica la possibilità di arrecare danno al veicolo e/o ai suoi componenti se le istruzioni riportate non vengono eseguite.



Note

Fornisce utili informazioni sull'operazione in corso.

Riferimenti

I particolari evidenziati in grigio e riferimento numerico (Es. ①) rappresentano l'accessorio da installare e gli eventuali componenti di montaggio forniti a kit.

I particolari con riferimento alfabetico (Es. A) rappresentano i componenti originali presenti sul motoveicolo.

Tutte le indicazioni destro o sinistro si riferiscono al senso di marcia del motociclo.

Avvertenze generali



Attenzione

Le operazioni riportate nelle pagine seguenti devono essere eseguite da un tecnico specializzato o da un'officina autorizzata DUCATI.



Attenzione

Le operazioni riportate nelle pagine seguenti se non eseguite a regola d'arte possono pregiudicare la sicurezza del pilota.



Note

Documentazione necessaria per eseguire il montaggio del Kit è il MANUALE OFFICINA, relativo al modello di moto in vostro possesso.



Note

Nel caso fosse necessaria la sostituzione di un componente del kit consultare la tavola ricambi allegata.

Symbols

To allow quick and easy consultation, this manual uses graphic symbols to highlight situations in which maximum care is required, as well as practical advice or information.

Pay attention to the meaning of the symbols since they serve to avoid repeating technical concepts or safety warnings throughout the text. The symbols should therefore be seen as real reminders. Please refer to this page whenever in doubt as to their meaning.



Warning

Failure to follow these instructions might give rise to a dangerous situation and provoke severe personal injuries or even death.



Caution

Failure to follow these instructions might cause damages to the vehicle and/or its components.



Notes

Useful information on the procedure being described.

References

Parts highlighted in grey and with a numeric reference (Example ①) are the accessory to be installed and any assembly components supplied with the kit.

Parts with an alphabetic reference (Example A) are the original components fitted on the vehicle.

Any right- or left-hand indication refers to the vehicle direction of travel.

General notes



Warning

Carefully perform the operations on the following pages since they might negatively affect rider safety.



Warning

Carefully perform the operations on the following pages since they might negatively affect rider safety.



Notes

The following documents are necessary for assembling the Kit: WORKSHOP MANUAL of your bike model.



Notes

Should it be necessary to change any kit parts, please refer to the attached spare part table.

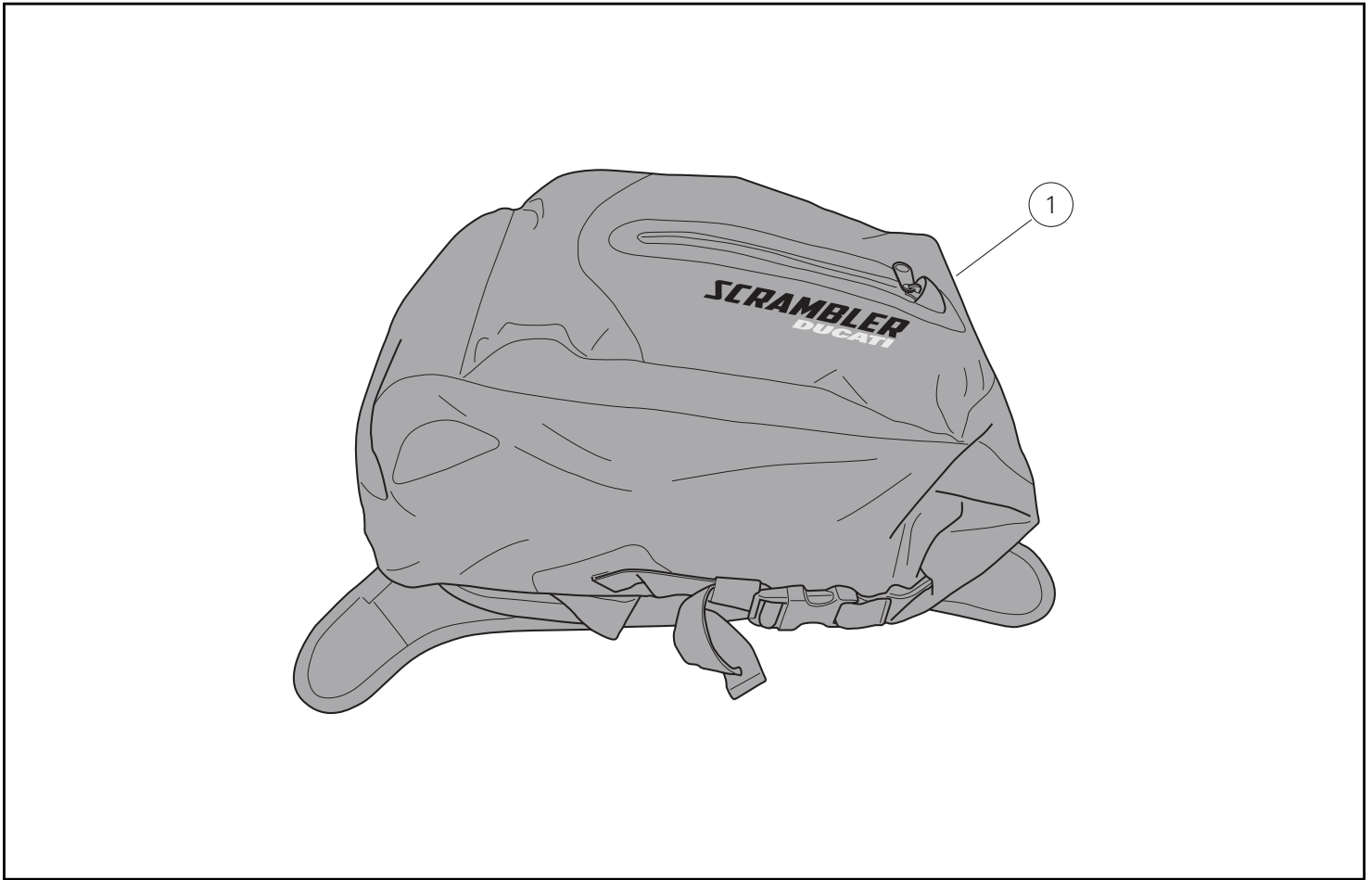

Pos.	Denominazione	Description
1	Borsa serbatoio magnetica	Magnetic tank bag

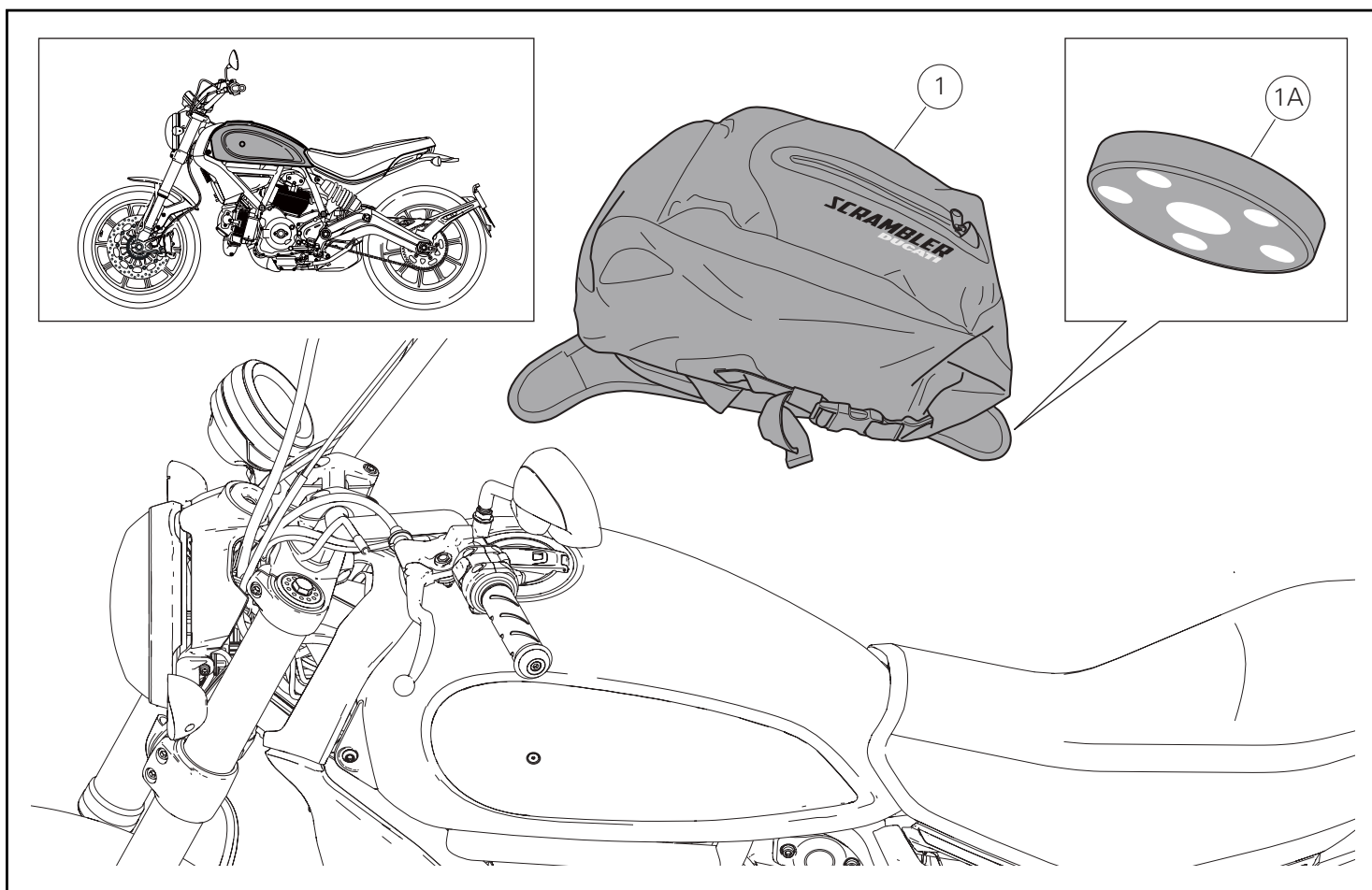

Montaggio componenti kit

● Importante

Verificare, prima del montaggio, che tutti i componenti risultino puliti e in perfetto stato.
Adottare tutte le precauzioni necessarie per evitare di danneggiare qualsiasi parte nella quale ci si trova ad operare.

Pulire accuratamente il serbatoio e il sottoborsa prima di ogni applicazione, residui di sporco potrebbero rigare la vernice.
Prestare attenzione che ad ogni rifornimento non ci siano residui di carburante tra il sottoborsa ed il serbatoio.

L'aggancio della borsa morbida (1) avviene tramite n.4 magneti removibili (1A).

● Importante

Non alloggiare tessere magnetiche (Bancomat, carte di credito, ecc.) all'interno della borsa.

Kit installation

● Caution

Check that all components are clean and in perfect condition before installation.
Adopt any precaution necessary to avoid damages to any part of the motorcycle you are working on.

Before installation, always clean thoroughly the tank as well as the area under the bag, as dirt residues might scratch the paint.
When refuelling, always make sure that no fuel residues are left between the tank and the area under the bag.

The soft bag (1) is secured using 4 removable magnets (1A).

● Caution

Do not put magnetic cards (Debit cards, credit cards, etc.) inside the bag.

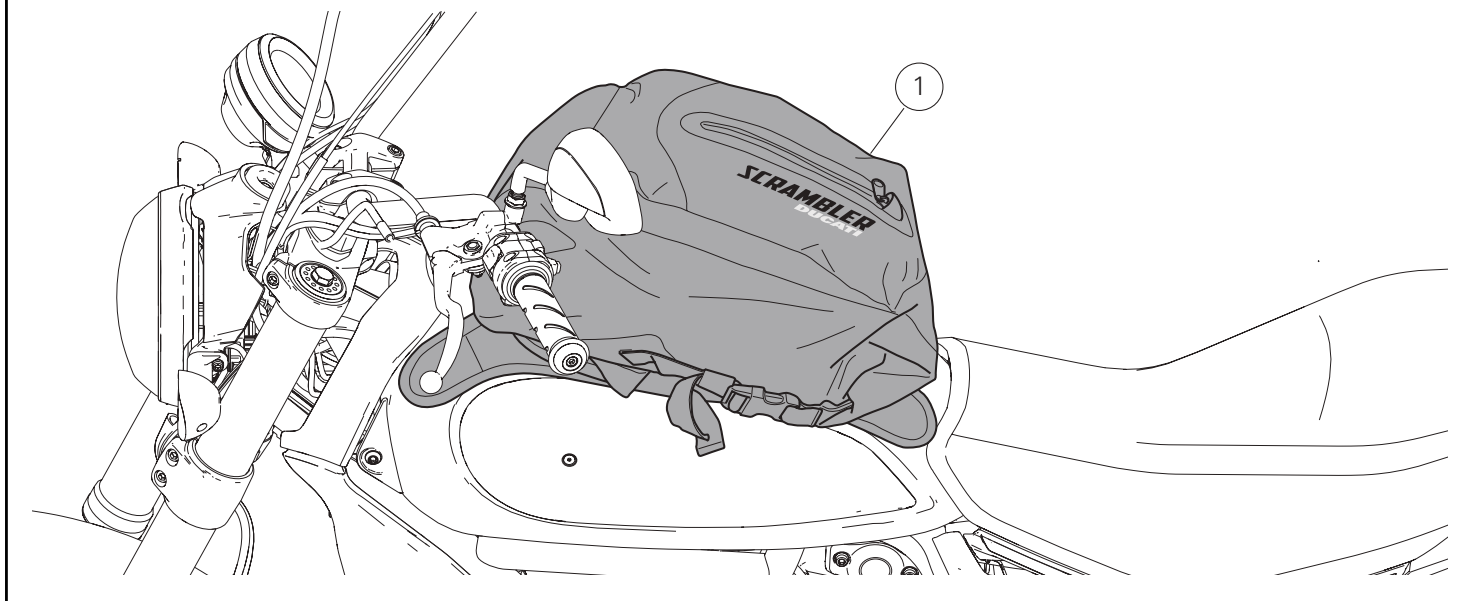
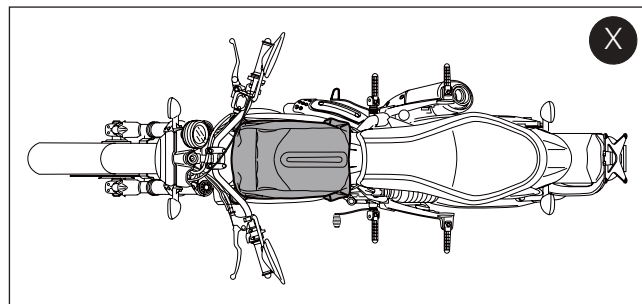
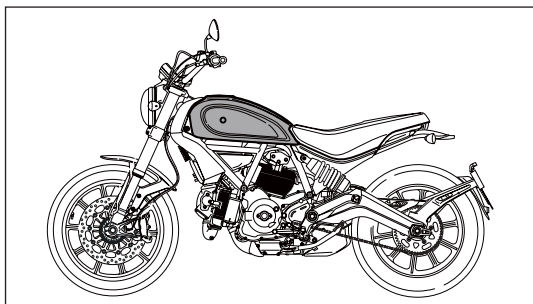

Posizionare la borsa (1) sul motoveicolo adottando la posizione dei magneti secondo la forma del serbatoio, come indicato in figura (X).

⚠ **Attenzione**

La borsa serbatoio non deve interferire con lo sterzo del motoveicolo o con la capacità del conducente di operare normalmente sui comandi direzionali.

⚠ **Attenzione**

È fatto obbligo di rispettare i limiti di velocità imposti dal paese in cui ci si trova a circolare e comunque è vietato oltrepassare i 130 Km/h con la borsa montata sulla moto poiché oltre si rischia il distacco della borsa stessa dal supporto.

⚠ **Attenzione**

Il peso massimo trasportabile dalla borsa è di 5 Kg. Nel caso si ecceda il peso consigliato si rischia la rottura della borsa stessa la quale può influire negativamente sulla sicurezza del pilota.

Quando si effettua il lavaggio della moto è necessario rimuovere la borsa.

Verifiche

Verificare il corretto aggancio della borsa serbatoio prima di mettersi in marcia.

Place bag (1) on motorcycle by positioning the magnets according to tank shape, as shown in the figure (X).

⚠ **Warning**

The tank bag must not interfere with the motorcycle steering or not prevent the rider from using turn indicators.

⚠ **Warning**

You are required to strictly comply with the speed limits of the country where you are riding; in any case, never exceed 130 Km/h when the bags are installed to the bike or the bag could detach from its support.

⚠ **Warning**

Maximum load that can be carried by the bag is 5 Kg. Do not exceed this limit or the bag might break thus jeopardizing rider safety.

When cleaning the bike it is necessary to remove the bag

Checks

Make sure the tank bag is properly secured before riding.

Kit sac de réservoir magnétique étanche OUTDOOR Kit magnettanktasche wasserdicht OUTDOOR



Symboles

Pour faciliter la consultation de ce manuel, des symboles signalent des situations exigeant le maximum d'attention, des conseils pratiques ou de simples informations. Lire attentivement la signification de ces symboles car ils renvoient à des concepts techniques ou des consignes de sécurité de la plus grande importance. Ils doivent être considérés comme de véritables « aide-mémoire ». Toujours consulter cette page en cas de doute concernant leur signification.



Attention

La non-observance des instructions reportées ci-dessous peut créer une situation dangereuse et provoquer de graves lésions personnelles voire la mort.



Important

Indique la possibilité d'endommager le véhicule et/ou ses composants si les instructions reportées ci-dessous ne sont pas suivies.



Remarques

Fournit des informations utiles sur l'opération en cours.

Références

Les pièces surlignées en gris et la référence numérique (Ex. ①) représentent l'accessoire à installer et les composants de montage éventuels fournis en kit.

Les pièces avec référence alphabétique (Ex. Ⓐ) représentent les composants d'origine présents sur le motorcycle.

Toutes les indications droite ou gauche se réfèrent au sens de marche la moto.

Avertissements généraux



Attention

Les opérations indiquées dans les pages suivantes, au cas où elles ne seraient pas effectuées selon les règles de l'art pourraient compromettre la sécurité du pilote.



Attention

Les opérations indiquées dans les pages suivantes, au cas où elles ne seraient pas effectuées selon les règles de l'art pourraient compromettre la sécurité du pilote.



Remarques

La documentation nécessaire pour effectuer la pose du Kit est le : MANUEL D'ATELIER, relatif au modèle de moto en votre possession.



Remarques

Au cas où il serait nécessaire d'effectuer le remplacement d'un composant du kit, il faudra consulter la planche relative aux pièces détachées ci-jointe.

Symbole

Zum schnellen und übersichtlichen Lesen werden Symbole verwendet, die außerordentlich wichtige Situationen, praktische Ratschläge oder auch nur einfache Informationen hervorheben. Der Bedeutung dieser Symbole ist besondere Aufmerksamkeit zu schenken, da sich hierdurch das ständige Wiederholen von technischen Konzepten oder Sicherheitshinweisen erübrigt. Sie stellen daher regelrechte „Merker“ dar. Diese Seite ist immer dann zur Hand zu nehmen, wenn Zweifel über die Bedeutung eines Symbols bestehen sollten.



Achtung

Eine Nichtbeachtung der hier wiedergegebenen Anweisungen kann Gefahrensituationen schaffen und zu schweren Verletzungen und auch zum Tod führen.



Wichtig

Weist darauf hin, dass bei Nichteinhaltung der hier wiedergegebenen Anweisungen die Möglichkeit für Schäden am Fahrzeug und/oder seiner Komponenten besteht.



Hinweis

Übermittelt nützliche Informationen zum betreffenden Arbeitseingriff.

Bezugsangaben

Die grau gekennzeichneten Bestandteile mit numerischem Bezug (Bsp. ①) geben das zu installierende Bestandteil und die eventuellen, im Kit enthaltenen Montagekomponenten wieder.

Die Bestandteile mit alphabetischem Bezug (Bsp. Ⓐ) geben die Original-Bestandteile wieder, die am Motorrad verbaut wurden.

Alle Angaben wie „rechts“ oder „links“ beziehen sich auf die Fahrtrichtung des Motorrads.

Allgemeine Warnhinweise



Achtung

Werden die auf den folgenden Seiten beschriebenen Arbeitsmaßnahmen nicht fachgerecht ausgeführt, kann sich dies auf die Sicherheit des Fahrers auswirken.



Achtung

Werden die auf den folgenden Seiten beschriebenen Arbeitsmaßnahmen nicht fachgerecht ausgeführt, kann sich dies auf die Sicherheit des Fahrers auswirken.



Hinweis

Für die Montage des Kits sind folgende Unterlagen erforderlich: WERKSTATTHANDBUCH, des sich in Ihrem Besitz befindlichen Motorrads.



Hinweis

Sollte sich der Austausch eines Bestandteils des Kits als erforderlich erweisen, ist dazu Bezug auf die beiliegende Ersatzteilliste zu nehmen.

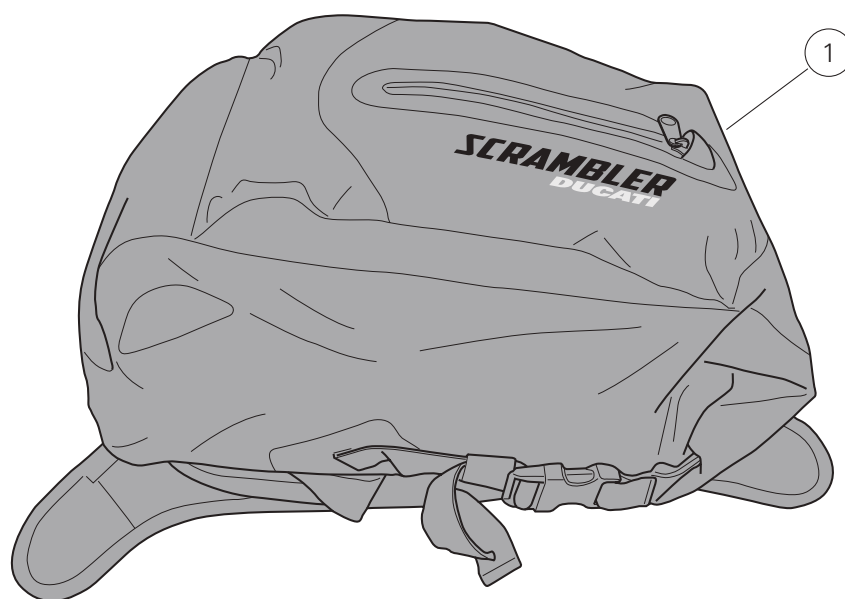

Pos.	Designation	Bezeichnung
1	Sac de réservoir magnétique	Magnettanktasche

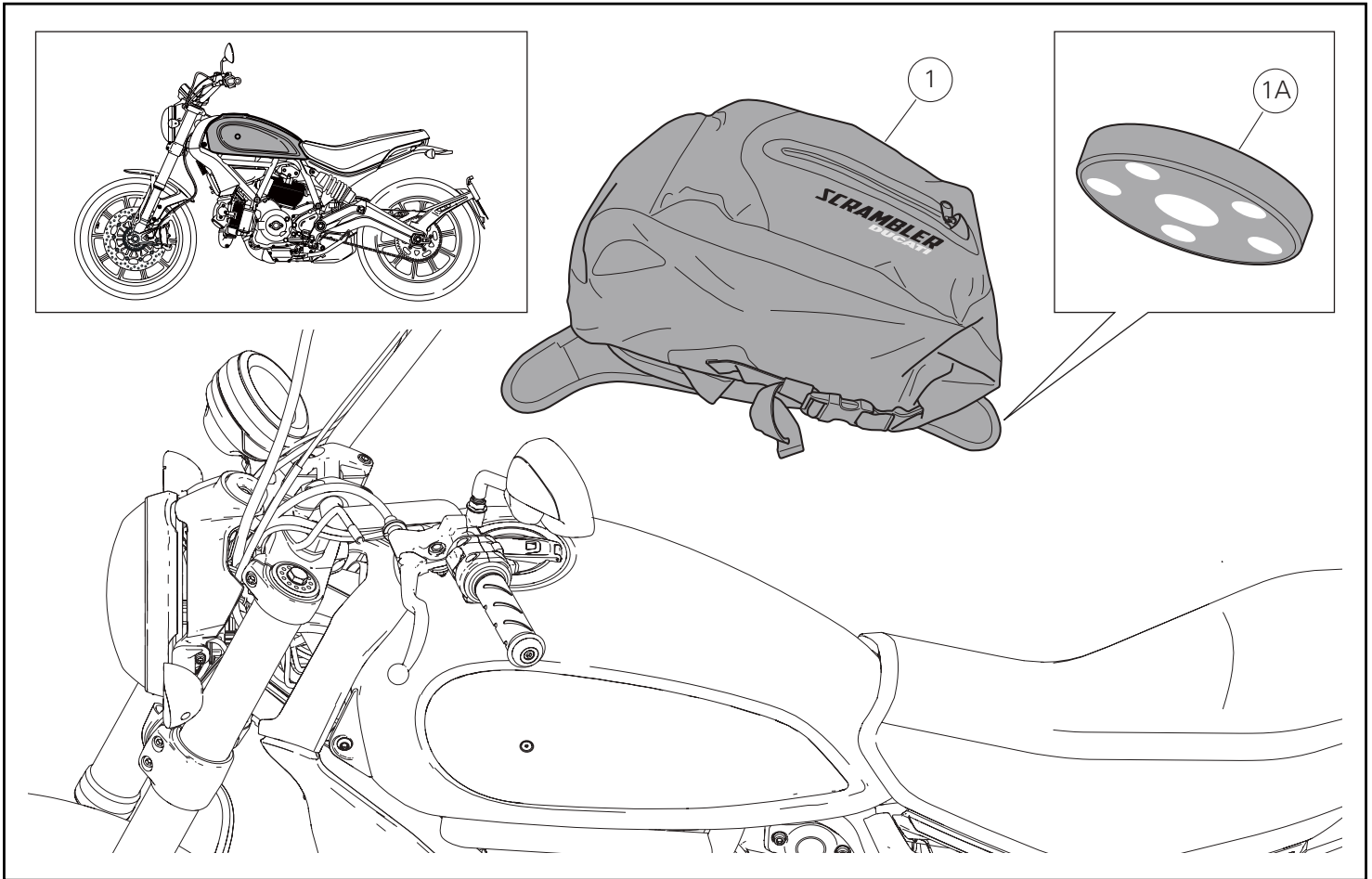

Pose composants kit

● Important

Vérifier, avant la pose, que tous les composants sont propres et en parfait état.

Adopter toutes les précautions nécessaires pour éviter d'endommager la surface externe des composants où on opère.

Nettoyer soigneusement le réservoir et le dessous de la sacoche avant chaque application pour éviter que des résidus de saleté puissent abîmer la peinture du réservoir.

Chaque fois que l'on s'arrête pour effectuer le ravitaillement en carburant, veiller à ce qu'il n'y ait aucun résidu de carburant entre le dessous de la sacoche et le réservoir.

L'accrochage du sac souple (1) est effectué à l'aide de 4 aimants amovibles (1A).

● Important

Ne pas mettre de cartes magnétiques dans le sac (cartes bancaires, etc.).

Montage der Komponenten des Kits

● Wichtig

Vor der Montage überprüfen, dass sich alle Komponenten im sauberen und perfekten Zustand befinden.

Alle erforderlichen Vorsichtsmaßnahmen treffen, um eine Beschädigung der Oberflächen der Komponenten, die vom Eingriff betroffen sind, zu vermeiden.

Den Tank und die Unterseite der Tasche vor jeder Montage sorgfältig reinigen, da Schmutzrückstände den Lack verkratzen könnten.

Beim Tanken stets darauf achten, dass keine Kraftstoffrückstände zwischen die Unterseite der Tasche und den Tank gelangen.

Die Verankerung der weichen Tanktasche (1) erfolgt mit 4 entfernbaren Magneten (1A).

● Wichtig

Magnetkarten (Scheckkarten, Kreditkarten etc.) nicht in dieser Tasche aufbewahren.

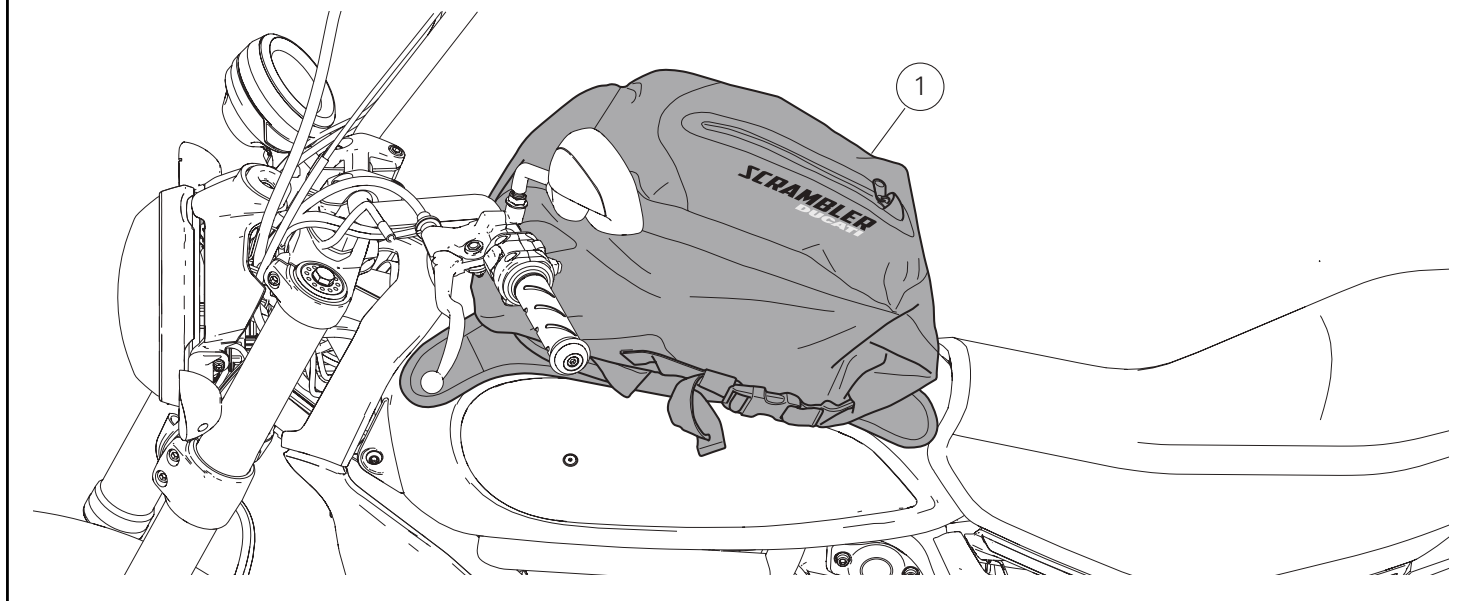
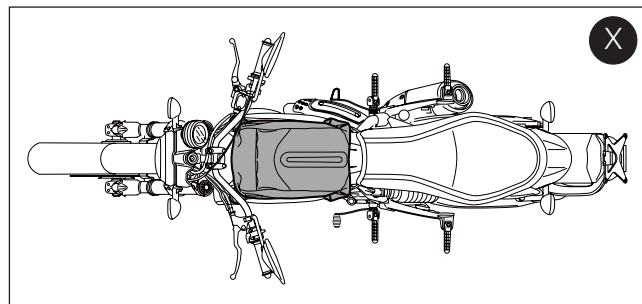
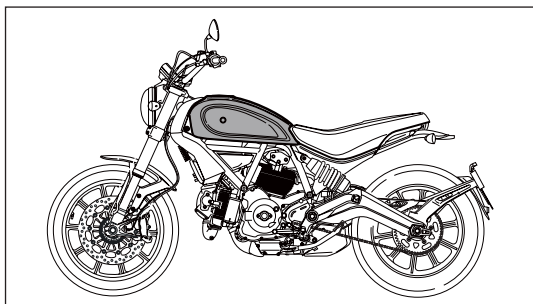

Positionner le sac (1) sur le motorcycle en ajustant la position des aimants selon la forme du réservoir, comme indiqué dans la figure (X).



Attention

Le sac de réservoir ne doit pas interférer avec la direction du motorcycle ou avec la capacité du pilote d'opérer normalement sur les commandes directionnelles.



Attention

Il est obligatoire de respecter les limites de vitesse en vigueur dans le pays où la moto circule et il est de toute façon interdit de dépasser 130 Km/h avec le sac placé sur la moto puisque à une vitesse supérieure le sac risquerait de se détacher du support.



Attention

Le poids maximum que le sac peut transporter est de 5 Kg. Dans le cas où le poids conseillé est dépassé, le risque est que le sac se rompt, ce qui pourrait avoir des conséquences négatives sur la sécurité du pilote.

Quand on effectue le lavage de la moto, il est nécessaire d'enlever le sac.

Vérifications

Vérifier que la sacoche de réservoir est bien fixée avant de se mettre en route.

Die Tasche (1) am Motorrad anordnen und dabei die Magnetposition, wie in Abbildung (X) angegeben, an die Tankform anpassen.



Achtung

Die Tanktasche darf nicht mit dem Lenker des Motorrads in Berührung kommen oder den Fahrer daran hindern, die Blinkersteuerung wie üblich zu verwenden.



Achtung

Es besteht die Pflicht die im Anwenderland geltenden Geschwindigkeitseinschränkungen einzuhalten, es sich auf jeden Fall verboten bei am Motorrad montierter Tasche die 130 km/h zu überschreiten, da es bei einer höheren Geschwindigkeit zum Lösen der Tasche von ihrem Halter kommen könnte.



Achtung

Das maximal in der Tasche transportierbare Gewicht beträgt 5 kg. Sollte das empfohlene Gewicht überschritten werden, könnte die Tasche reißen, was sich auf die Sicherheit des Fahrers auswirken kann.

Vor der Motorradwäsche müssen die Tasche entfernt werden.

Überprüfungen

Vor dem Losfahren stets die korrekte Verankerung der Tanktasche

Conjunto bolsa para depósito magnética hermética OUTDOOR Sealed magnetic tank bag kit - OUTDOOR



Símbolos

Para uma leitura rápida e racional, foram utilizados símbolos que evidenciam situações de máxima atenção, conselhos práticos ou simples informações. Preste muita atenção ao significado dos símbolos, pois a sua função é a de evitar a repetição de conceitos técnicos ou de avisos de segurança. Portanto, os símbolos devem ser considerados como verdadeiros "lembretes". Consulte esta página sempre que tiver dúvidas acerca do seu significado.



Atenção

O não cumprimento das instruções mostradas pode criar uma situação de perigo e causar graves lesões pessoais e até mesmo a morte.



Importante

Indica a possibilidade de causar danos ao veículo e/ou aos seus componentes se as instruções mostradas não forem executadas.



Notas

Fornisce utili informazioni sull'operazione in corso.

Referências

Os detalhes evidenciados em cinza e com referência numérica (Ex. ①) representam o acessório a ser instalado e os eventuais componentes de montagem fornecidos como kit.

Os detalhes com referência alfabética (Ex. A) representam os componentes originais presentes na moto.

Todas as indicações direita ou esquerda, referem-se ao sentido de marcha da moto.

Advertências gerais



Atenção

As operações mostradas nas páginas a seguir, se não forem executadas com boa técnica, podem prejudicar a segurança do condutor.



Atenção

As operações mostradas nas páginas a seguir, se não forem executadas com boa técnica, podem prejudicar a segurança do condutor.



Notas

Documentação necessária para executar a montagem do Conjunto: MANUAL DE OFICINA, relativo ao modelo de moto em sua posse.



Notas

Caso seja necessária a substituição de um componente do conjunto, consulte o quadro de peças de reposição em anexo.

Symbols

To allow quick and easy consultation, this manual uses graphic symbols to highlight situations in which maximum care is required, as well as practical advice or information.

Pay attention to the meaning of the symbols since they serve to avoid repeating technical concepts or safety warnings throughout the text. The symbols should therefore be seen as real reminders. Please refer to this page whenever in doubt as to their meaning.



Warning

Failure to follow these instructions might give raise to a dangerous situation and provoke severe personal injuries or even death.



Caution

Failure to follow these instructions might cause damages to the vehicle and/or its components.



Notes

Useful information on the procedure being described.

References

Parts highlighted in grey and with a numeric reference (Example ①) are the accessory to be installed and any assembly components supplied with the kit.

Parts with an alphabetic reference (Example A) are the original components fitted on the vehicle.

Any right- or left-hand indication refers to the vehicle direction of travel.

General notes



Warning

Carefully perform the operations on the following pages since they might negatively affect rider safety.



Warning

Carefully perform the operations on the following pages since they might negatively affect rider safety.



Notes

The following documents are necessary for assembling the Kit: WORKSHOP MANUAL of your bike model.



Notes

Should it be necessary to change any kit parts, please refer to the attached spare part table.

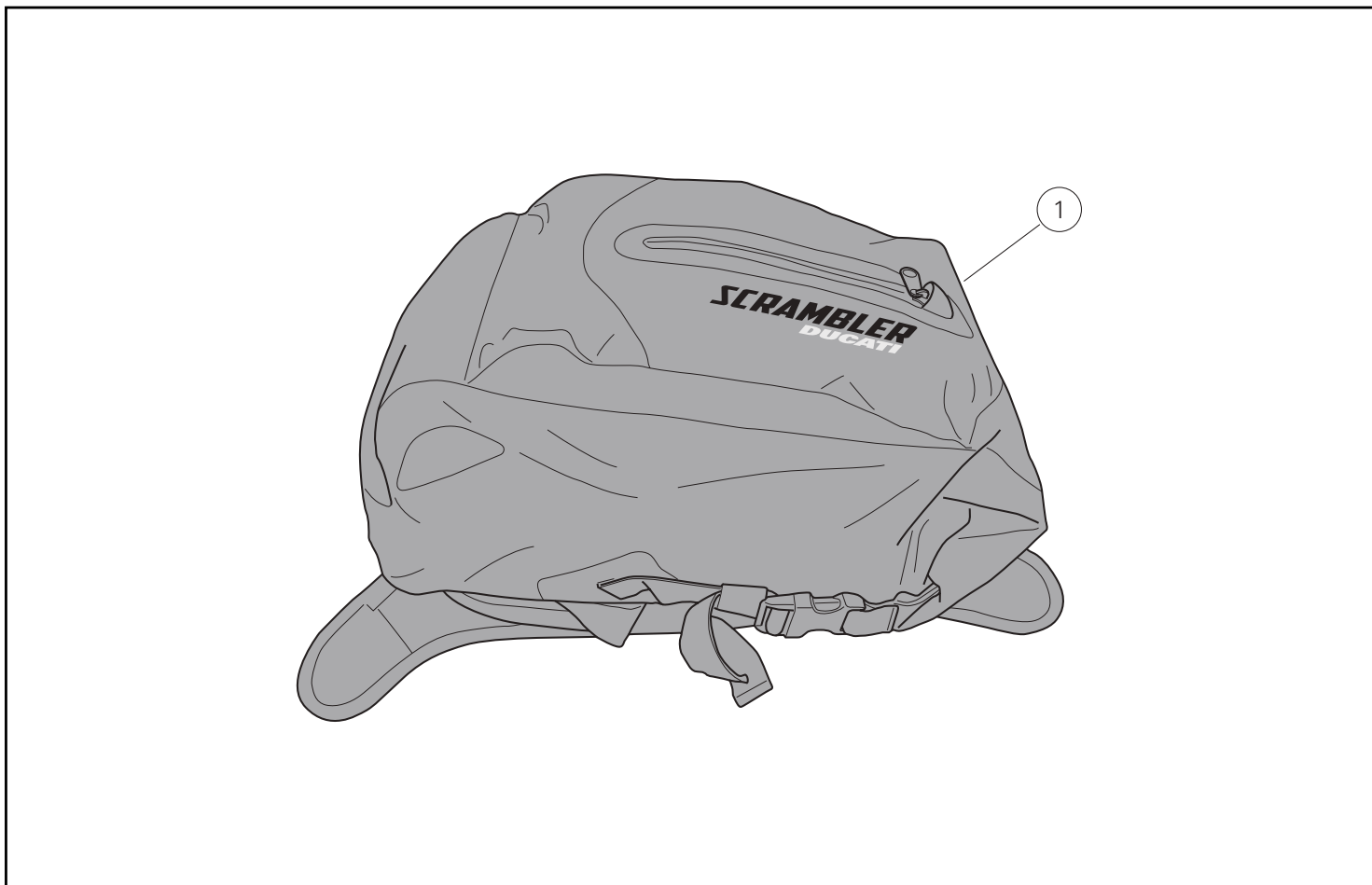

Pos.	Descrição	Description
1	Bolsa para depósito magnética	Magnetic tank bag

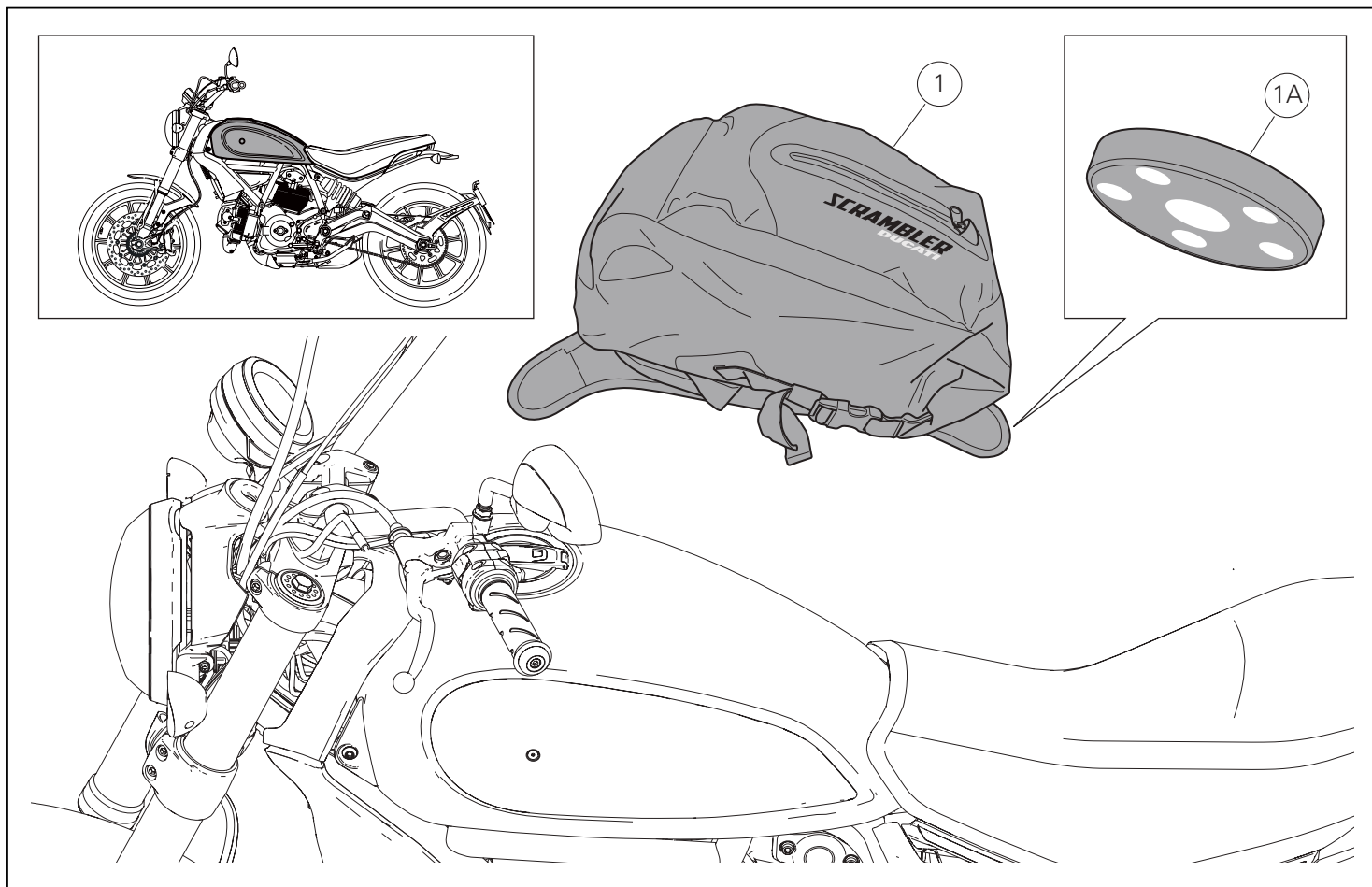

Montagem dos componentes

● Importante

Verifique, antes da montagem, se todos os componentes estão limpos e em perfeito estado.

Adote todas as precauções necessárias para evitar danificar qualquer peça com a qual deve trabalhar.

Limpe cuidadosamente o depósito e a parte debaixo da bolsa antes de cada aplicação, resíduos de sujeira podem riscar a pintura.

Preste atenção para que durante cada abastecimento não existam resíduos de combustível entre a parte debaixo da bolsa e o depósito.

O engate da bolsa macia (1) ocorre através de n.4 ímãs removíveis (1A).

● Importante

Não colocar cartões magnéticos (cartões de débito, cartões de crédito, etc.) dentro da bolsa.

Kit installation

● Caution

Check that all components are clean and in perfect condition before installation.

Adopt any precaution necessary to avoid damages to any part of the motorcycle you are working on.

Before installation, always clean thoroughly the tank as well as the area under the bag, as dirt residues might scratch the paint.

When refuelling, always make sure that no fuel residues are left between the tank and the area under the bag.

The soft bag (1) is secured using 4 removable magnets (1A).

● Caution

Do not put magnetic cards (Debit cards, credit cards, etc.) inside the bag.

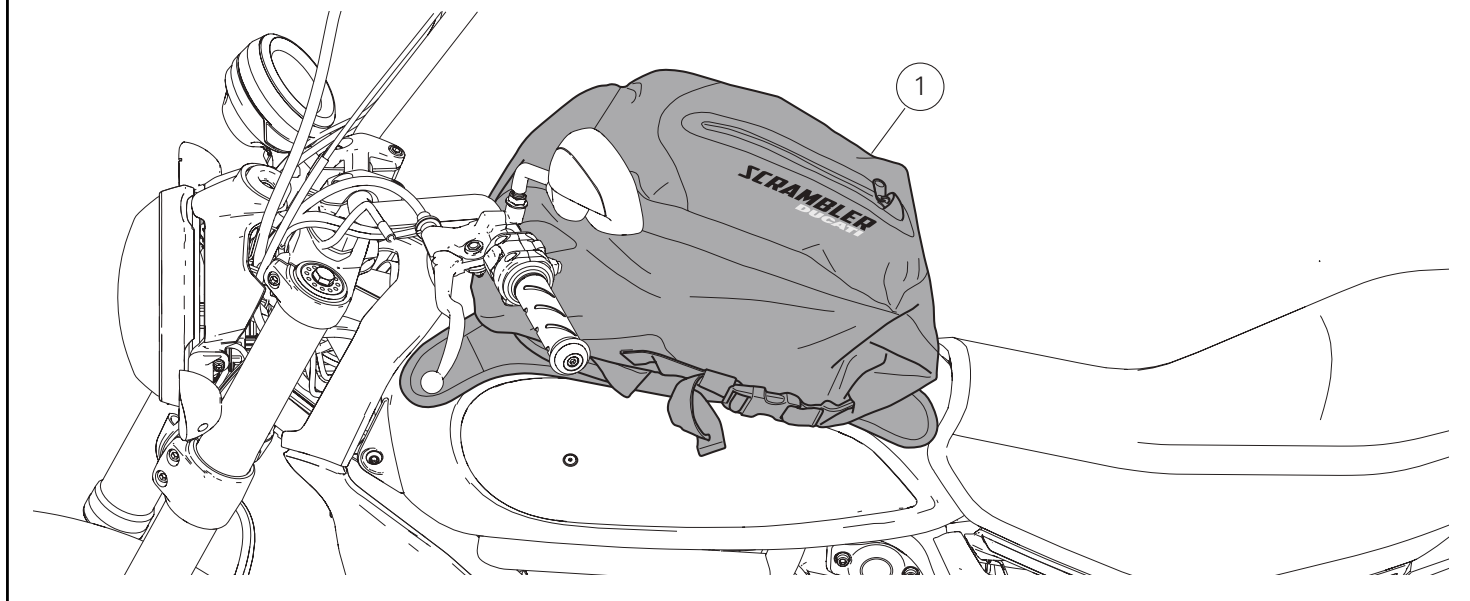
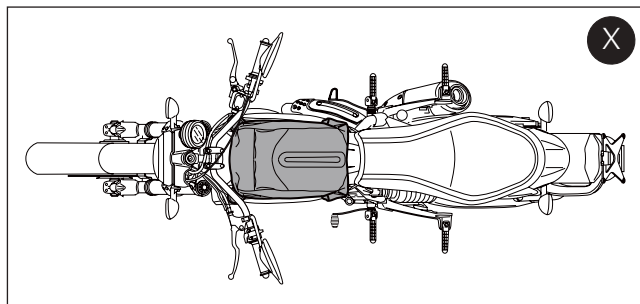
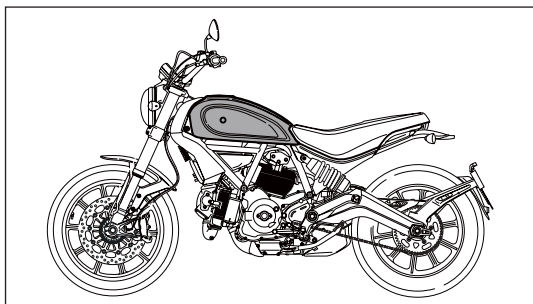

Posicione a bolsa (1) na moto, adotando a posição dos ímãs conforme a forma do depósito, como o indicado na figura (X).



Atenção

A bolsa para depósito não deve interferir na direção da moto ou na capacidade do condutor de atuar normalmente nos comandos de direção.



Atenção

É obrigatório respeitar os limites de velocidade impostos pelo país onde circula com a moto e, de qualquer maneira, é proibido ultrapassar os 130 Km/h com a bolsa montada na moto, pois, para além dessa velocidade, corre-se o risco de separação da bolsa do suporte.



Atenção

O peso máximo transportável pela bolsa é de 5 Kg. Se exceder o peso aconselhado, risca-se o rompimento da bolsa, que pode influenciar negativamente a segurança do condutor.

Quando efetuar a lavagem da moto, será necessário remover a bolsa.

Verificações

Verifique o correto engate da bolsa para depósito antes de iniciar uma viagem.

Place bag (1) on motorcycle by positioning the magnets according to tank shape, as shown in the figure (X).



Warning

The tank bag must not interfere with the motorcycle steering or not prevent the rider from using turn indicators.



Warning

You are required to strictly comply with the speed limits of the country where you are riding; in any case, never exceed 130 Km/h when the bags are installed to the bike or the bag could detach from its support.



Warning

Maximum load that can be carried by the bag is 5 Kg. Do not exceed this limit or the bag might break thus jeopardizing rider safety.

When cleaning the bike it is necessary to remove the bag

Checks

Make sure the tank bag is properly secured before riding.

Kit bolsa depósito magnética estanca OUTDOOR アウトドアマグネット防水タンクバッグキット



Símbolos

Para una lectura rápida y racional se han empleado símbolos que evidencian situaciones de máxima atención, consejos prácticos o simples informaciones. Prestar mucha atención al significado de los símbolos porque su función consiste en omitir la repetición de conceptos técnicos o advertencias de seguridad. Los símbolos deben considerarse como verdaderos "apuntes". Consultar esta página cada vez que se tengan dudas sobre su significado.



Atención

El incumplimiento de las instrucciones indicadas puede crear una situación de peligro y ocasionar graves lesiones e incluso la muerte.



Importante

Indica la posibilidad de provocar un daño al vehículo y/o a sus componentes si no se siguen las instrucciones indicadas.



Notas

Suministra útiles informaciones sobre la operación en curso.

Referencias

Las partes resaltadas en gris y la referencia numérica (Por ej. ①) representan el accesorio que se debe instalar y los eventuales componentes de montaje suministrados en el kit.

Las partes con referencia alfabética (Por ej. Ⓐ) representan los componentes originales presentes en la motocicleta.

Todas las indicaciones derecha o izquierda se refieren al sentido de marcha de la motocicleta.

Advertencias generales



Atención

Las operaciones descritas en las siguientes páginas deben realizarse correctamente para no perjudicar la seguridad del piloto.



Atención

Las operaciones descritas en las siguientes páginas deben realizarse correctamente para no perjudicar la seguridad del piloto.



Notas

La documentación necesaria para realizar el montaje del Kit es el: MANUAL DE TALLER, relativo al modelo de moto en vuestro poder.



Notas

Si fuera necesario sustituir un componente del kit, consultar la tabla de recambios adjunta.

シンボル

素早くかつ合理的に読み進めることができるように、本マニュアルではいくつかのシンボルを導入し、最大限の注意を払う必要がある状況や、推奨事項、または一般情報を明確にしています。技術的概念や安全に関する警告を繰り返し記載する必要がないように機能しているため、各シンボルの意味に十分注意してください。シンボルは、実際上の“覚え書き”であると考えてください。シンボルなどの意味がわからなくなったり疑問に思う場合は、必ずこのページで調べるようにしてください。



注記

この説明書に従わずに使用すると危険な状況を招き、重大なけが、あるいは死をももたらす原因となることがあります。



重要

この説明書に従わずに使用すると、車体及び/ 又はその部品に損害を招く可能性があります。



参考

操作中の内容に関する有用な情報を掲載しています。

参照

灰色で表示する部品、および参照番号 (Es. ①) で表示する部品は、キットに付属する取り付け部品および組み立て部品を示します。

参照アルファベット (Es. Ⓐ) で表示する部品は、車両に付属するオリジナル部品を示します。

すべての右及び左の指示は車体の進行方向を向いたものです。

一般警告事項



警告

以下のページに記載されている作業が規定通りに実施されない場合、ライダーの安全性を脅かすおそれがあります。



警告

以下のページに記載されている作業が規定通りに実施されない場合、ライダーの安全性を脅かすおそれがあります。



参考

キットの取り付けに必要な資料：お手持ちの車両モデルに対応するワークショップマニュアル。



参考

キットの部品を交換する必要がある場合は、添付のスペアパーツ表を参照してください。

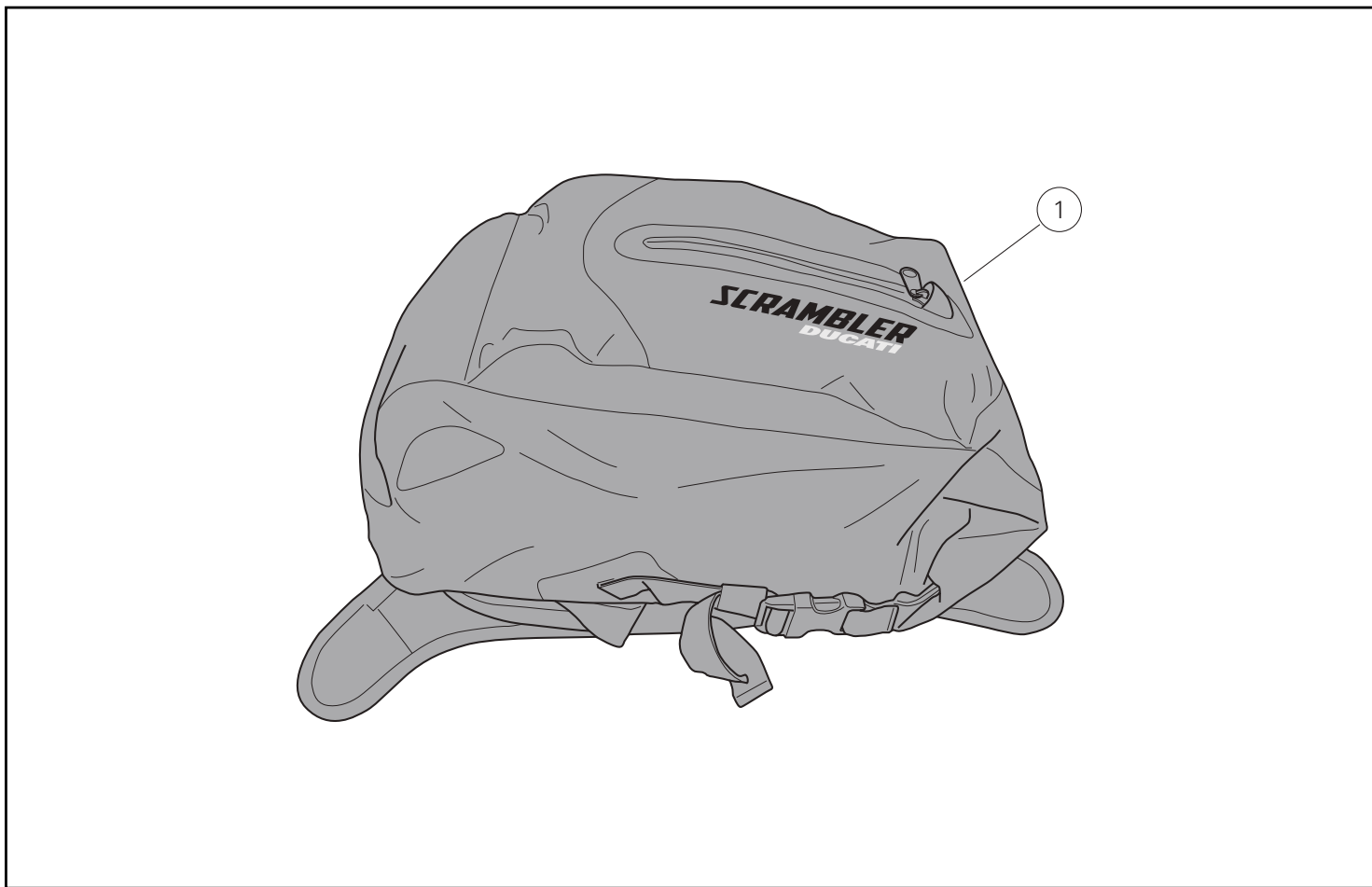

Pos.	Denominacion	説明
1	Bolsa para depósito magnética	マグネット式タンクバッグ

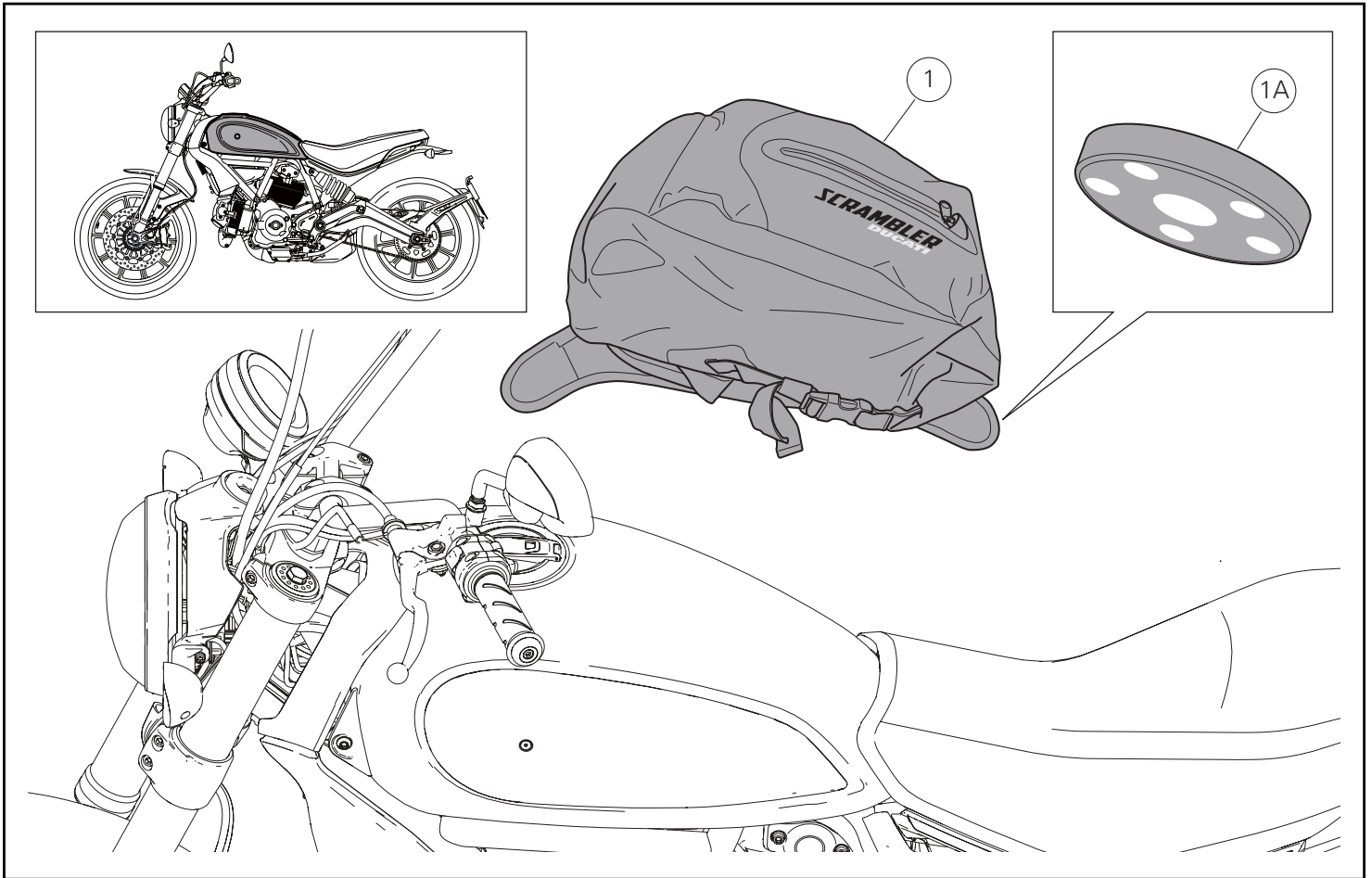

Montaje componentes kit

● Importante

Controlar, antes del montaje, que todos los componentes se encuentren limpios y en perfecto estado. Adoptar todas las precauciones necesarias para evitar daños en la superficie exterior de los componentes donde se debe operar.

Limpiar cuidadosamente el depósito y la parte debajo de la bolsa antes de cada aplicación ya que los residuos de suciedad podrían dañar la pintura.

Prestar atención a no dejar residuos de combustible entre el depósito y la parte de abajo de la bolsa tras cada reposición.

El enganche de la bolsa suave (1) se realiza a través de 4 imanes extraíbles (1A).

● Importante

No colocar tarjetas magnéticas (tarjetas de débito y de crédito, etc.) dentro de la bolsa.

キット部品の取り付け

● 重要

取り付け前にすべての部品に汚れがなく、完璧な状態であることを確認します。作業する部品の外側表面を傷つけないために、必要な予防措置を取ってください

取り付け前にフューエルタンクおよびバッグ下を入念に清掃します。汚れが残っていると塗装に傷をつけてしまうことがあります。

燃料補給の際は毎回、バッグ下とフューエルタンクの間に燃料が付着しないように注意してください。

ソフトバッグ (1) の取り付けは、4 つの取外し可能なマグネット (1A) で行います。

● 重要

磁気カード (キャッシュカードやクレジットカードなど) をバッグの中に入れてください。

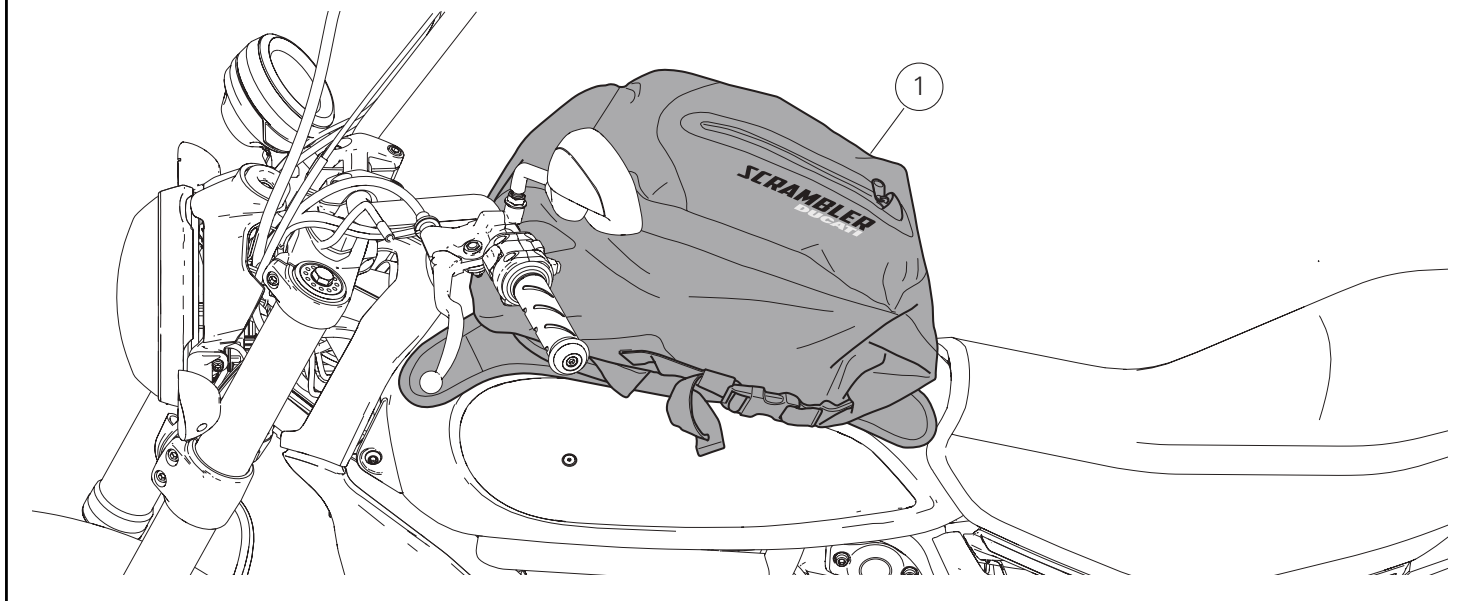
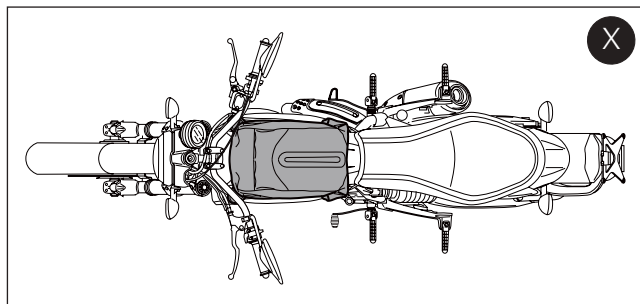
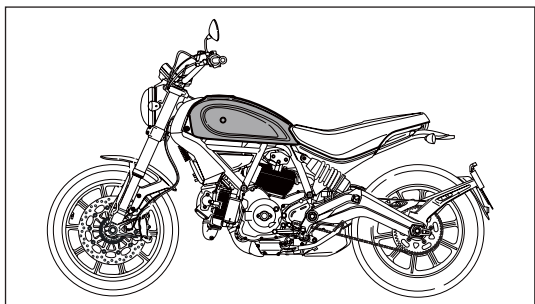

Posicionar la bolsa (1) en la motocicleta adoptando la posición de los imanes, de acuerdo con la forma del depósito, como indica la figura (X).

⚠ Atención

La bolsa depósito no debe interferir con el movimiento del manillar de la motocicleta o con la capacidad del piloto para operar normalmente sobre los mandos de dirección.

⚠ Atención

Es obligatorio respetar los límites de velocidad establecidos por el país donde se circula, además se prohíbe superar los 130 Km/h con la bolsa montada en la moto porque se corre el riesgo que se desprenda del soporte.

● Importante

El peso máximo que se puede transportar en la bolsa es de 5 Kg. En el caso que se exceda el peso recomendado se corre el riesgo que la bolsa se rompa e influya de manera negativa en la seguridad del piloto.

Cuando se realiza el lavado de la moto es necesario quitar la bolsa.

Controles

Controlar que la bolsa se enganche correctamente en el depósito antes de emprender la marcha.

バッグ (1) を車両に取り付けます。このとき図 (X) のように、フューエルタンクの形状に合わせてマグネットの位置を調整してください。

⚠ 警告

フューエルタンクバッグは、車両のハンドル操作に支障がないように、またライダーの運転の妨げにならないように取り付けてください。

⚠ 警告

運転する国で定められた最高速度を守る義務があり、バッグがマウントから外れる危険があるので、いずれの場合も車体にバッグを取り付けた状態では130 Km/hを超えるスピードで運転してはなりません。

● 重要

バッグの最大運搬重量は5Kg です。推奨重量を超えると、バッグが破損する危険があり、ライダーの安全を脅かすことがあります。車体を洗浄するときにはバッグ及びマウントを取り外す必要があります。

確認

フューエルタンクバッグは、車両のハンドル操作に支障がないように、またライダーの運転の妨げにならないように取り付けてください。



DUCATI PERFORMANCE accessories

レース専用部品 ご注文書

ご注文商品

1 P/N

商品名

2 P/N

商品名

3 P/N

商品名

4 P/N

商品名

5 P/N

商品名

お客様ご記入欄

私は上記レース専用部品を下記車両に装着し、サーキット走行のみに利用し、一般公道には利用しません。

車台番号 ZDM

モデル名

お客様署名

ご注文日

ドゥカティ正規ネットワーク店記入欄

お客様に上記レース専用部品を販売し、レース専用部品のご利用方法を説明いたしました。

販売店署名

販売日

年

月

日

販売店様へお願い

- 上記ご記入の上、弊社アフターセールス部までFAXしてください。FAX:03-6692-1317
- 取り付け車両1台に1枚でご使用ください。